



MOVER 270 D EVO T5

(1106400; 1106401; 1106402; 1106403; 1106404; 1106405)

- I** POMPA PER SOTTOFONDI
Manuale uso e manutenzione
- F** POMPE POUR CHAPES
Manuel d'utilisation et d'entretien
- GB** SCREED PUMP
Use and maintance manual
- D** MÖRTELPUMPE
Betriebs- und Wartungsanleitung
- E** BOMBA PARA SOLERAS
Manual de uso y mantenimiento



3238064_R03_(2024/06)

IMER International S.p.A.

Via Salceto, 53-55 - 53036 Poggibonsi (SI) Italy

Tel. +39 0577 97341 - Fax +39 0577 983304

imergroup.com

Equipment Division

Via della Meccanica, 39 (Zona Industriale Sentino)

53040 Rapolano Terme (SI) Italy

Tel. +39 0577 97341 - Fax +39 0577 704047



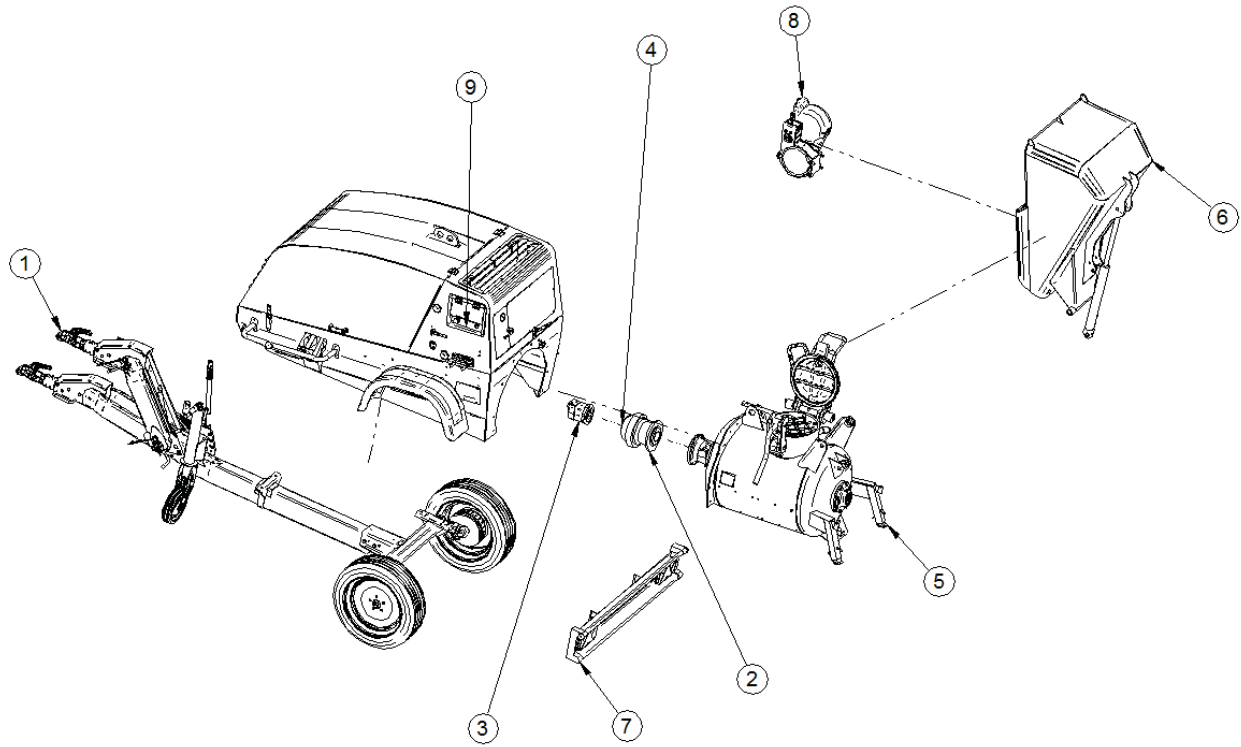

Fig. 14

Rif.	Cod.	I	F	GB	D	E	Note
1	3235716	ASSALE STRADALE	ESSIEU À LA ROUTIER	AXLE TO ROAD	ACHSE STRAßENVERKEHR	EJE DE LA CARRETERA	
1	3236195	ASSALE NON STRADALE AXLE NOT TO ROAD	ESSIEU PAS À LA ROUTIER	AXLE NOT TO ROAD	ACHSE NICHT ZUM STRAßENVERKEHR	EJE NO A LA CARRETERA	
2	3229092	RIDUTT. RR510 FS/5/00	RÉDUCT. RR510 FS/5/00	REDUCER RR510 FS/5/00	GETRIEBEMOTOR RR510 FS/5/00	REDUCT. RR510 FS/5/00	
3	3228281	MOTORE IDR. HRC XX200 B4 M09 DB001 N	MOTEUR HYDR. HRC XX200 B4 M09 DB001 N	HYDR. MOTOR HRC XX200 B4 M09 DB001 N	HYDR. MOTOR HRC XX200 B4 M09 DB001 N	MOTOR HIDR. HRC XX200 B4 M09 DB001 N	
4	3227897	O-RING	JOINT TORIQUE	O-RING	O-RING	JUNTA TÓRICA	
5	3234401	SERBATOIO MOVER 270 E-D (USCITA DRIITA)	RÉSERVOIR MOVER 270 E-D (SORTIE DROITE)	TANK MOVER 270 E-D (STRAIGHT OUTPUT)	MISCHBEHÄLTER MOVER 270 E-D (GERADER AUSGANG)	DEPÓSITO MOVER 270 E-D (SALIDA RECTA)	
6	3223769	BENNA MOVER 270 VERNICIATA (Errore. L'origine riferimento non è stata trovata.)	BENNE MOVER 270 PEINTE (Errore. L'origine riferimento non è stata trovata.)	BUCKET MOVER 270 PAINTED (Errore. L'origine riferimento non è stata trovata.)	BESCHICKER MOVER 270 LACKIERT (Errore. L'origine riferimento non è stata trovata.)	CUCHARA MOVER 270 PINTADA (Errore. L'origine riferimento non è stata trovata.)	
7	3223944	BARRA LUCI	BARRE ÉCLAIRAGE	LIGHTS BAR	LEUCHTENLEISTE	BARRA DE LUCES	
8	3223896	RIAVVOLGICAVO MOVER 270 D	ENROULEUR CÂBLES MOVER 270 D	CABLE WINDER MOVER 270 D	KABELROLLE MOVER 270 D	ENROLLADOR CABLE MOVER 270 D	
9	3235507	PANNELLO COMANDI MOVER 270 D EVO	TABLEAU COMMANDES MOVER 270 D EVO	CONTROL PANEL MOVER 270 D EVO	BEDIENFELD MOVER 270 D EVO	PANEL DE MANDOS MOVER 270 D EVO	

Documentazione senza certificazione CE
 Documentation without CE certificate

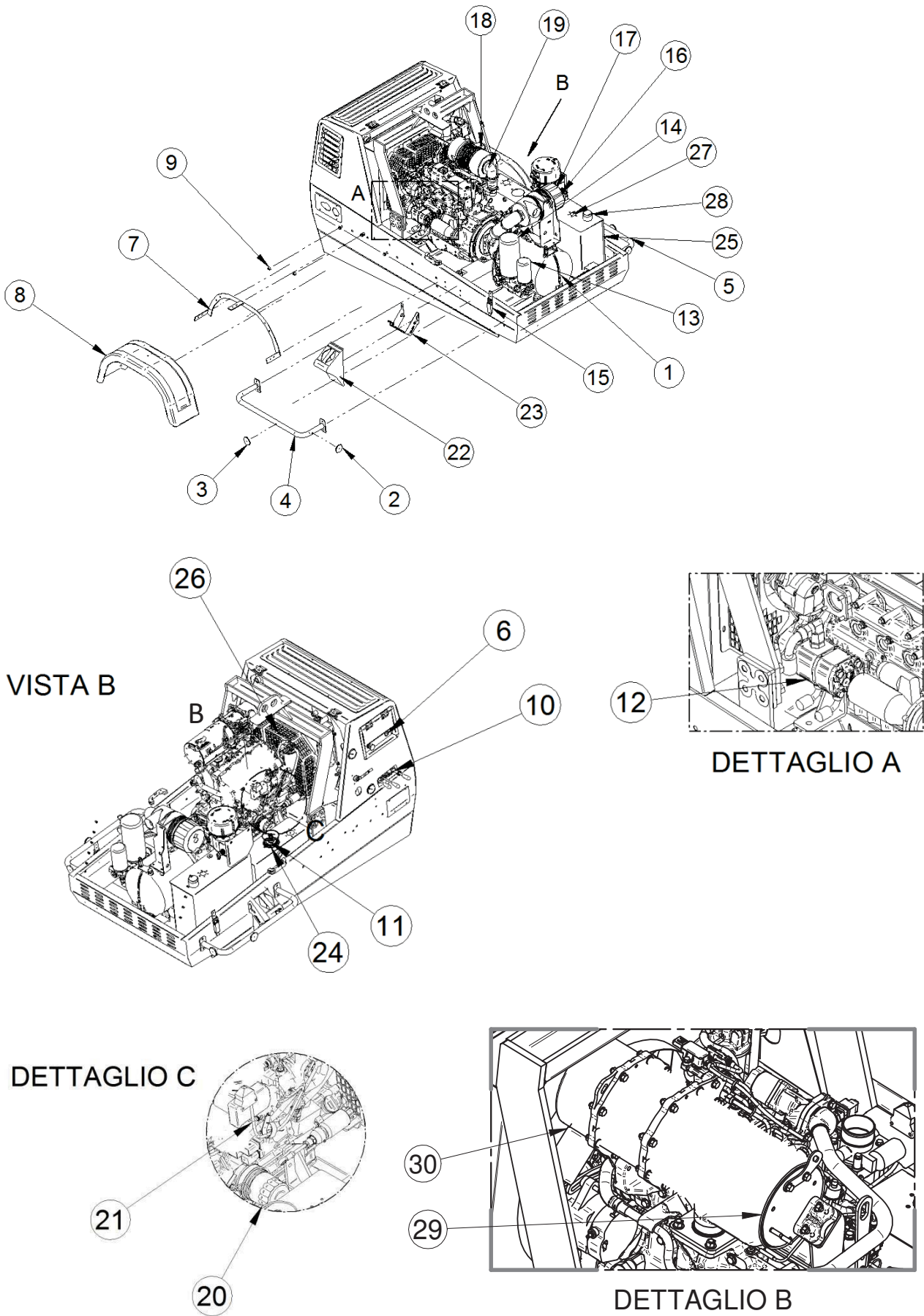
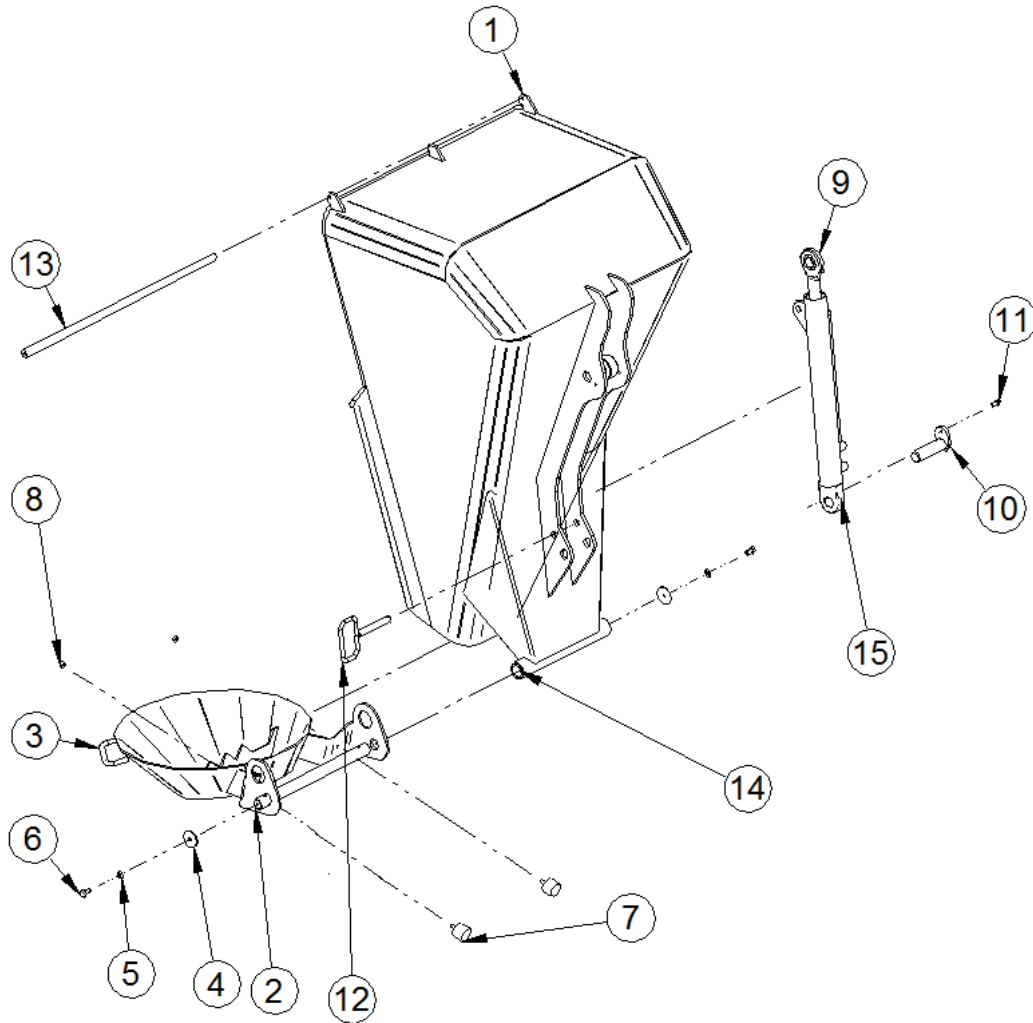

Fig. 15

Rif.	Cod.	I	F	GB	D	E	Note
1	3235502	COMPRESSORE	COMPRESSEUR	COMPRESSOR	KOMPRESSOR	COMPRESOR	
2	3224854	CATADIOTTO BIANCO	CATADIOPTRE BLANC	WHITE REFLECTOR	RÜCKSTRAHLER WEISS	CATADIÓPTICO BLANCO	
3	3224855	CATADIOTTO GIALLO	CATADIOPTRE JAUNE	YELLOW REFLECTOR	RÜCKSTRAHLER GELB	CATADIÓPTICO AMARILLO	
4	3223947	BARRA ANTICICLISTA SX	BARRE ANTICYCLISTE G	LH MOVABLE SIDE IMPACT BAR	ANTIZYKLUSSTANGE LINKS	BARRA ANTICICLISTA IZD	
5	3226182	BARRA ANTICICLISTA DX	BARRE ANTICYCLISTE D	RH MOVABLE SIDE IMPACT BAR	ANTIZYKLUSSTANGE RECHTS	BARRA ANTICICLISTA DCH	
6	3235507	PANNELLO COMANDI MOVER 270 D EVO	TABLEAU COMMANDES MOVER 270 D EVO	CONTROL PANEL MOVER 270 D EVO	BEDIENFELD MOVER 270 D EVO	PANEL DE MANDOS MOVER 270 D EVO	
7*	3223946	SUPP. PARAFANGHI MOVER 270.	SUPP. GARDE-BOUE MOVER 270.	MUDGUARD SUPPORT MOVER 270.	HALTERUNG KOTFLÜGEL MOVER 270.	SOP. GUARDABARROS MOVER 270	
8*	3223945	PARAFANGO IN PLASTICA MOVER	GARDE-BOUE EN PLASTIQUE MOVER	PLASTIC MUDGUARD MOVER	KUNSTSTOFFKOTFLÜGEL MOVER	GUARDABARROS DE PLÁSTICO MOVER	
9*	3213469	DISTANZIALE 20X12X12,5 Z	ENTRETOISE 20X12X12,5 Z	SPACER 20X12X12,5 Z	DISTANZSTÜCK 20X12X12,5 Z	DISTANCIADOR 20X12X12,5 Z	
10	3235506	DISTRIBUTORE	DISTRIBUTEUR	DISTRIBUTOR	VERTEILER	DISTRIBUIDOR	
11	3235929	CARTUCCIA FILTRO OLIO RITORNO POMPA	CARTOUCHE FILTRE À HUILE RETOUR POMPE	PUMP RETURN OIL FILTER CARTRIDGE	FILTERPATRONE ÖLRÜCKLAUF PUMPE	CARTUCHO DEL FILTRO DEL ACEITE DE RETORNO BOMBA	
12	3235504	POMPA IDRAULICA MOTORE MOVER 270 D EVO	POMPE HYDRAULIQUE MOTEUR MOVER 270 D EVO	HYDRAULIC PUMP MOTOR MOVER 270 D EVO	HYDRAULIKPUMPE MOTOR MOVER 270 D EVO	BOMBA HIDRÁULICA MOTOR MOVER 270 D EVO	
13	3235954	FILTRO OLIO COMPRESSORE	FILTRE HUILE COMPRESSEUR	COMPRESSOR OIL FILTER	ÖLFILTER KOMPRESSOR	FILTRO DEL ACEITE DEL COMPRESOR	
14	3235957	FILTRO DISOLEATORE	FILTRE DÉSHUILEUR	OIL EXTRACTOR FILTER	FILTER ÖLABSCHEIDER	FILTRO DESOLEADOR	
15	3225311	CHIUSURA A LEVE	FERMETURE PAR LEVIERS	LEVER CLOSURE	HEBELVERSCHLUSS	CIERRE CON PALANCAS	
16	3235955	CARTUCCIA FILTRO ARIA COMPRESSORE 1° STADIO	CARTOUCHE FILTRE AIR COMPRESSEUR 1er ÉTAGE	1ST STAGE COMPRESSOR AIR CLEANER CARTRIDGE	LUFTFILTERPATRONE KOMPRESSOR 1. STUFE	CARTUCHO DEL FILTRO DEL AIRE DEL COMPRESOR 1ª FASE	
17	3235956	CARTUCCIA FILTRO ARIA COMPRESSORE 2° STADIO	CARTOUCHE FILTRE AIR COMPRESSEUR 1ème ÉTAGE	2ND STAGE COMPRESSOR AIR CLEANER CARTRIDGE	LUFTFILTERPATRONE KOMPRESSOR 2. STUFE	CARTUCHO DEL FILTRO DEL AIRE DEL COMPRESOR 2ª FASE	
18	3235950	CARTUCCIA FILTRO ARIA MOTORE 1° STADIO	CARTOUCHE FILTRE AIR MOTEUR 1er ÉTAGE	1ST STAGE MOTOR AIR CLEANER CARTRIDGE	LUFTFILTERPATRONE MOTOR 1. STUFE	CARTUCHO DEL FILTRO DEL AIRE DEL MOTOR 1ª FASE	
19	3235951	CARTUCCIA FILTRO ARIA MOTORE 2° STADIO	CARTOUCHE FILTRE AIR MOTEUR 2ème ÉTAGE	2ND STAGE MOTOR AIR CLEANER CARTRIDGE	LUFTFILTERPATRONE MOTOR 2. STUFE	CARTUCHO DEL FILTRO DEL AIRE DEL MOTOR 2ª FASE	
20	3234374	CARTUCCIA FILTRO OLIO MOTORE	CARTOUCHE DE FILTRE HUILE MOTEUR	ENGINE OIL FILTER CARTRIDGE	MOTORÖLFILTERKARTUSCHE	CARTUCHO DE FILTRO DEL ACEITE DEL MOTOR	
21	3234373	CARTUCCIA FILTRO GASOLIO	CARTOUCHE FILTRE GAZOLE	FUEL FILTER CARTRIDGE	DIESELÖL- FILTERKASSETTE	CARTUCHO FILTRO GASÓLEO	
22	3224101	CUNEO ARRESTO TRAINO	CÔNE ARRÊT REMORQUAGE	TOWING STOP WEDGE	STOPP-KONUS ANHÄNGER	CUÑA TOPE REMOLQUE	
23	3224141	SUPPORTO CUNEO	SUPPORT CÔNE	WEDGE SUPPORT	KONUSHALTERUNG	SOPORTE CUÑA	
24	3235528	FILTRO OLIO	FILTRE À HUILE	OIL FILTER	ÖLFILTER	FILTRO ACEITE	
25	3235802	SERBATOIO GASOLIO	RÉSERVOIR GAZOLE	FUEL TANK	DIESELÖL-TANK	DEPÓSITO DEL GASÓLEO	
26	3235501	VENTOLA RADIATORE	VENTILATEUR RADIATEUR	RADIATOR FAN	KÜHLERLÜFTER	VENTILADOR DEL RADIADOR	
27	3225671	GALLEGGIANTE SERBATOIO	FLOTTEUR RÉSERVOIR	TANK FLOAT	SCHWIMMER MISCHBEHÄLTER	FLOTADOR DEPÓSITO	
28	3233283	TAPPO SERBATOIO	BOUCHON RÉSERVOIR	TANK CAP	DECKEL MISCHBEHÄLTER	TAPÓN DEPÓSITO	
29	3238031	COPERTURA DPF	COUVERTURE DU FAP	DPF COVERAGE	DPF-ABDECKUNG	COBERTURA DPF	
30	3238032	COPERTURA COLLETTORE SCARICO DPF	COUVERCLE DE COLLECTEUR D'ÉCHAPPEMENT DPF	DPF EXHAUST MANIFOLD COVER	DPF AUSPUFFKRUMME RABDECKUNG	CUBIERTA DEL COLLECTOR DE ESCAPE DPF	

Tab. 10 (Fig. 15)



Rif.	Cod.	I	F	GB	D	E	Note
1	3223769	BENNA MOVER 270 VERNICIATA	BENNE MOVER 270 PEINTE	BUCKET MOVER 270 PAINTED	BESCHICKER MOVER 270 LACKIERT	CUCHARA MOVER 270 PINTADA	
2	3223803	PERNO FISSO BENNA ZINCATO	AXE FIXE BENNE ZINGUÉ	GALVANIZED BUCKET FIXED PIN	FIXBOLZEN BESCHICKER VERZINKT	PERNO FIJO CUCHARA GALVANIZADO	
3	3223800	CONVOGLIATORE INERTI BENNA VERNICIATO	CONVOYEUR INERTES BENNE PEINT	PAINTED BUCKET AGGREGATES CONVEYOR	FÖRDERANLAGE ZUSCHLAGSTOFFE BESCHICKER VERZINKT	CONDUCTO ÁRIDOS CUCHARA PINTADO	
4	1224113	ROSETTA PIANA 10X50X3 Z	RONDELLE PLATE 10X50X3 Z	FLAT WASHER 10X50X3 Z	FLACHE U-SCHEIBE	ARANDELA PLANA 10X50X3 Z	
5	2224340	ROSETTA 6592 M10X20 Z DIN125A	RONDELLE 6592 M10X20 Z DIN125A	WASHER 6592 M10X20 Z DIN125A	U-SCHEIBE 6592 M10X20 Z DIN125A	ARANDELA 6592 M10X20 Z DIN125A	
6	2222077	VITE TE 8.8 5739 8X 20	VIS TE 8.8 5739 8X 20	HEX HEAD SCREW 8.8 5739 8X 20	SCHRAUBE TE 8.8 5739 8X 20	TORNILLO TE 8.8 5739 8X 20	
7	3225091	ANTIVIBRANTE D.40 H.30 M8X23	ANTI-VIBRATION D.40 H.30 M8X23	VIBRATION DAMPER D.40 H.30 M8X23	SCHWINGUNGSDÄMPFER D.40 D.40 H.30 M8X23	AMORTIGUADOR D.40 H.30 M8X23	
8	2223570	DADO 5588 DIAM.8 Z	ÉCROU 5588 DIAM.8 Z	NUT 5588 DIAM.8 Z	MUTTER 5588 DURCHM.8 Z	TUERCA 5588 DIAM.8 Z	
9	3223912	PISTONE D.EFFETTO D.60 CORSA 410	PISTON D.EFFET D.60 COURSE 410	DOUBLE-ACTING PISTON D.60 STROKE 410	KOLBEN D.WIRKUNG D.60 HUB 410	PISTÓN D.EFECTO D.60 CARRERA 410	
10	3223905	PERNO BLOCCAGGIO PISTONE ZINCATO	BOULON BLOCAGE PISTON ZINGUÉ	GALVANIZED PISTON LOCK PIN	SPERRBOLZEN KOLBEN VERZINKT	PERNO BLOQUEO PISTÓN GALVANIZADO	
11	2222060	VITE TE, M 8 X 20 Z	VIS TE, M 8 X 20 Z	HEX HEAD SCREW, M 8 X 20 Z	SCHRAUBE TE, M 8 X 20 Z	TORNILLO TE, M 8 X 20 Z	
12	3224624	MANIGLIA BLOCCAGGIO BENNA ZINCATA	POIGNÉE BLOCAGE BENNE ZINGUÉE	GALVANIZED BUCKET LOCK HANDLE	SPERRGRIF BESCHICKER VERZINKT	MANILLA BLOQUEO CUCHARA GALVANIZADA	
13	3223927	RULLO SCORRIMENTO CAVO PALA RASCHIANTE ZINC.	ROULEAU COULISSEMENT CÂBLE PALE DE RACLAGE ZING.	GALVANIZED SCRAPER CABLE SLIDING ROLLER	KABELGLEITROLLE SCHAUFEL VERZINKT	RODILLO DESLIZAMIENTO CABLE PALA RASCADORA GALV.	
14	3223805	BOCCOLA	DOUILLE	BUSHING	BUCHSE	CASQUILLO	
15	3223909	INGRASSATORE	GRAISSEUR	LUBRICATOR	SCHMIERBÜCHSE	ENGRASADOR	

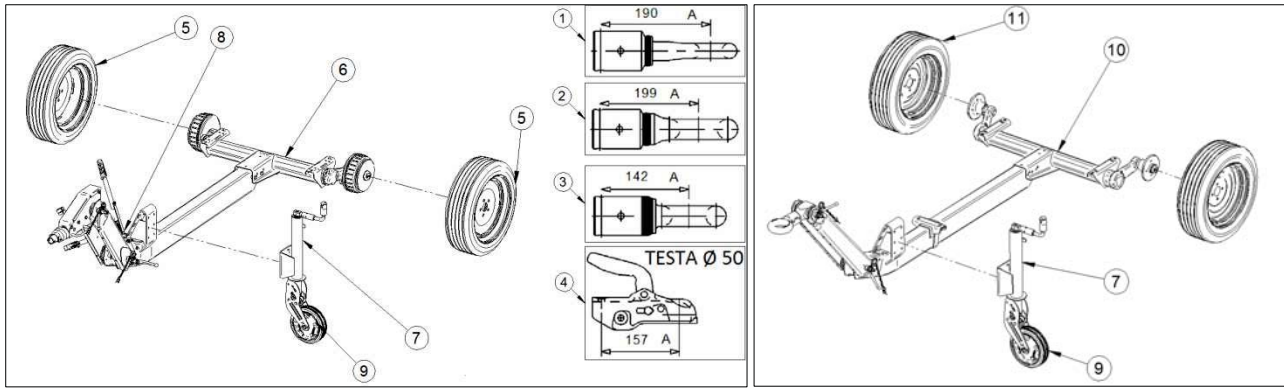

Fig. 16

Ref.	Cod.	I	F	GB	D	E	Note
1	3234181	OCCHIONE ITALIA OPTIONAL 45x31	ANNEAU ITALIE EN OPTION 45x31	TOWING EYE FOR ITALY OPTIONAL 45x31	ÖSE ITALIEN OPTIONAL 45x31	ARGOLLA ITALIA OPCIONAL 45x31	
2	3234179	OCCHIONE OPTIONAL DIN D.40	ANNEAU EN OPTION DIN D.40	TOWING EYE OPTIONAL DIN D.40	ÖSE OPTIONAL DIN D.40	ARGOLLA OPCIONAL DIN D.40	
3	3234180	OCCHIONE FRANCIA OPTIONAL 68x42	ANNEAU FRANCE EN OPTION 68x42	TOWING EYE FRANCE OPTIONAL 68x42	ÖSE FRANKREICH OPTIONAL 68x42	ARGOLLA FRANCIA OPCIONAL 68x42	
4	3234178	GIUNTO A SFERA D.50 AK300	JOINT À BILLE D.50 AK300	BALL JOINT D.50 AK300	KUGELGELENK D.50 AK300	RÓTULA D.50 AK300	
5	3224847	RUOTA	ROUE	WHEEL	RAD	RUEDA	195 R14C
6	3235716	ASSALE STRADALE	ESSIEU À LA ROUTIER	AXLE TO ROAD	ACHSE STRAßENVERKEHR	EJE DE LA CARRETERA	
7	3234894	RUOTINO STRADALE	PETITE ROUE ROUTE	COMPACT SPARE TYRE	STRASSENERSATZRAD	RUEDA PEQUEÑA CARRETERA	
8	3235969	CAVO FRENO	CÂBLE FREIN	BRAKE CABLE	KABEL BREMSE	CABLE FRENO	
9	3235968	RUOTA RUOTINO	ROUE PETITE ROUE	SPARE TYRE WHEEL	ERSATZRAD	RUEDA PARA RUEDA PEQUEÑA CARRETERA	
10	3236195	ASSALE NON STRADALE AXLE NOT TO ROAD	ESSIEU PAS À LA ROUTIER	AXLE NOT TO ROAD	ACHSE NICHT ZUM STRAßENVERKEHR	EJE NO A LA CARRETERA	
11	3225536	RUOTA	ROUE	WHEEL	RAD	RUEDA	205/65 R15

Tab. 11 (Fig. 16)

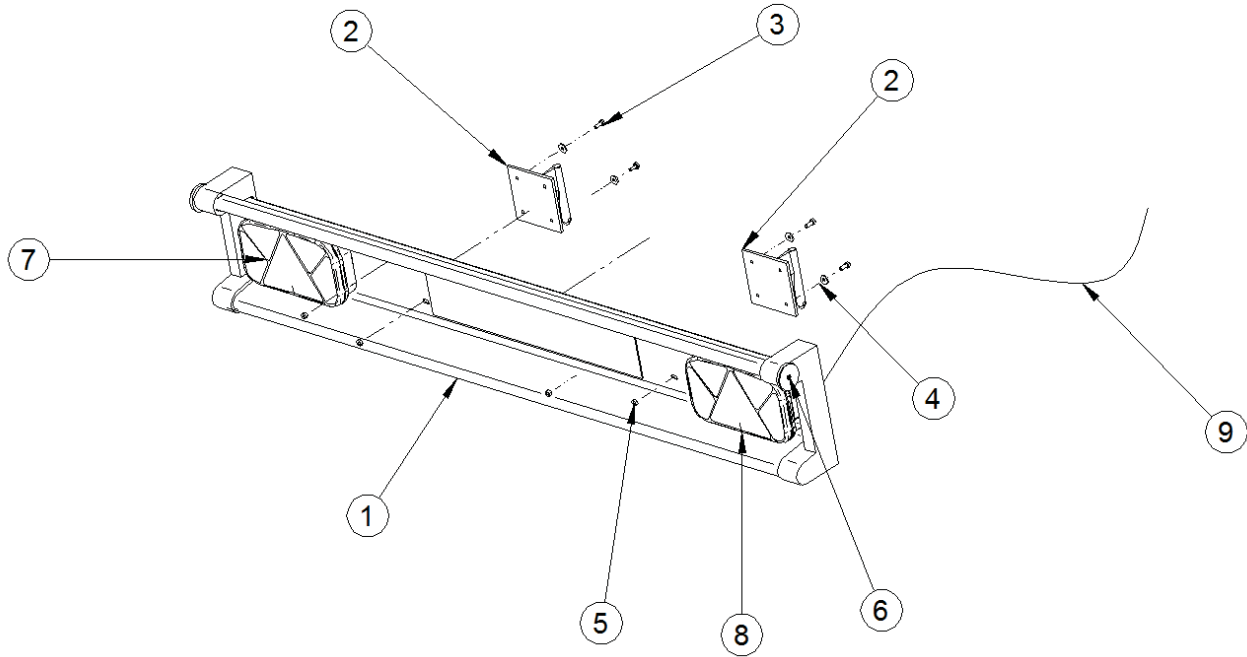

Fig. 17

Ref.	Cod.	I	F	GB	D	E	Note
1	3223944	BARRA LUCI	BARRE ÉCLAIRAGE	LIGHTS BAR	LEUCHTENLEISTE	BARRA DE LUCES	
2	3235449	SUPPORTO BARRA LUCI	SUPPORT BARRE ÉCLAIRAGE	LIGHTS BAR SUPPORT	HALTERUNG LEUCHTENLEISTE	SOPORTE BARRA LUCES	
3	2222021	VITE TEFR 8.8 5739 6X 16 Z	VIS TEFR 8.8 5739 6X 16 Z	HEX HEAD FLANGED SCREW 8.8 5739 6X 16 Z	SCHRAUBE TEFR 8.8 5739 6X 16 Z	TORNILLO TEFR 8.8 5739 6X 16 Z	
4	2224531	ROSETTA 6593 DIAM. 6X18 Z	RONDELLE 6593 DIAM. 6X18 Z	WASHER 6593 DIAM. 6X18 Z	U-SCHEIBE 6593 DURCHM. 6X18 Z	ARANDELA 6593 DIÁM. 6X18 Z	
5	2223280	DADO 5588 DIAM.6 Z	ÉCROU 5588 DIAM.6 Z	NUT 5588 DIAM.6 Z	MUTTER 5588 DURCHM.6 Z	TUERCA 5588 DIÁM. 6 Z	
6	3224855	CATADRIOTTO GIALLO	CATADIOPTRE JAUNE	YELLOW REFLECTOR	RÜCKSTRAHLER GELB	CATADIÓPTRICO AMARILLO	
7	3224520	FANALE MULTIPOINT Sx	LANTERNE MULTIPOINT G	LH MULTIPOINT LIGHT	SCHEINWERFER MULTIPOINT links	FARO MULTIPOINT IZD.	
8	3224519	FANALE MULTIPOINT Dx	LANTERNE MULTIPOINT D	RH MULTIPOINT LIGHT	SCHEINWERFER MULTIPOINT rechts	FARO MULTIPOINT DCH.	
9	3223943	CAVO 12V 7mt SPINE 7 POLI	CÂBLE 12 V 7 m FICHES 7 PÔLES	CABLE 12V 7m PINS 7 POLES	KABEL 12V 7mt STECKER 7 POLE	CABLE 12V 7m CLAVIJAS 7 POLOS	

Tab. 12 (Fig. 17)

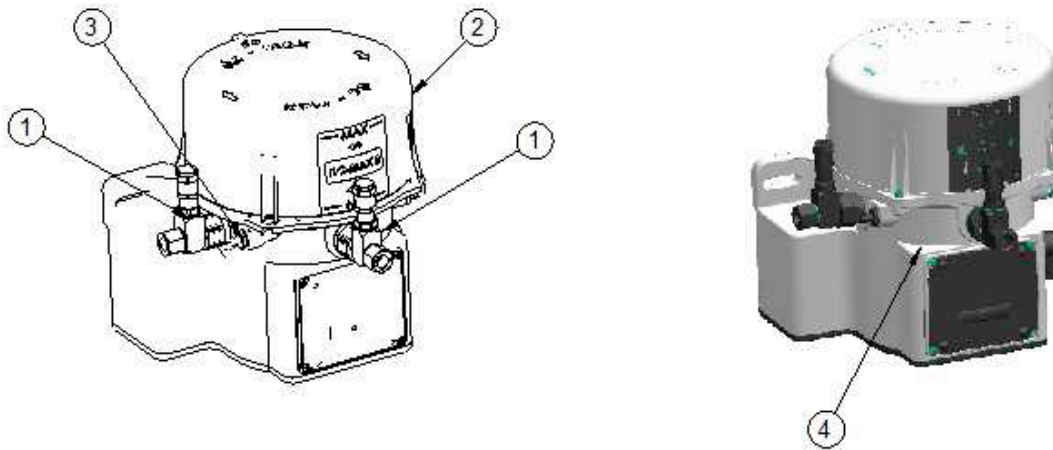
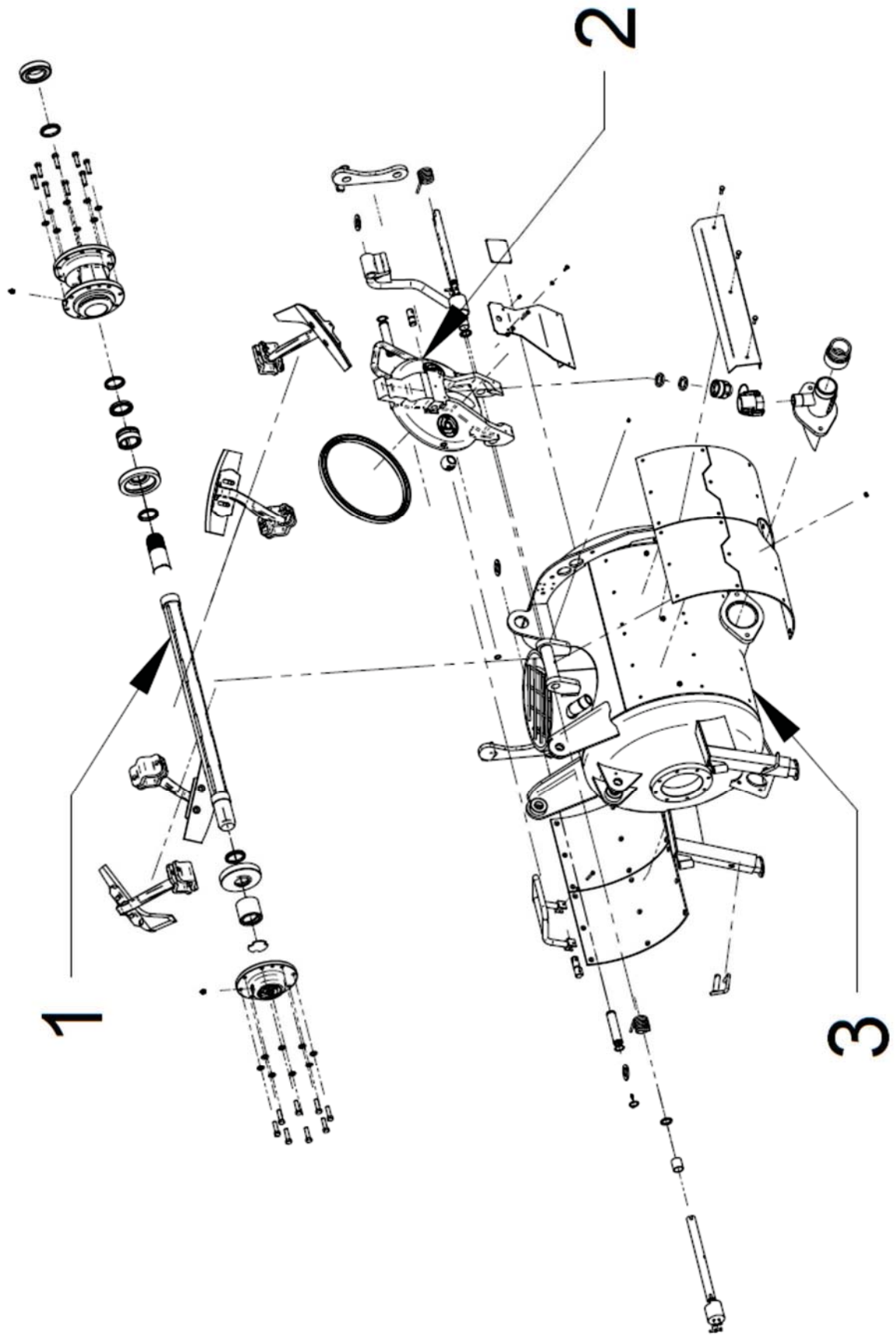

Fig. 18

Ref.	Cod.	I	F	GB	D	E	Note
1	3237095	POMPANTE	POMPANT	PUMPING UNIT	PUMPEINHEIT	SISTEMA DE BOMBEO	
2	3226725	SERBATOIO	RÉSERVOIR	TANK	MISCHBEHÄLTER	DEPÓSITO	
3	-----	INGRASSATORE	GRAISSEUR	LUBRICATOR	SCHMIERBÜCHSE	ENGRASADOR	
4	3233980	ELET.POMPA GRASSO	ÉLECT.POMPE GRAISSE	GREASE PUMP ELECT.	ELEKT. PUMPE FETT	ELECT.BOMBA GRASA	

Tab. 13 (Fig. 18)

Documentazione senza certificazione CE
Documentation without CE certificate



REF. 1

Documentazione senza certificazione CE
Documentation without CE certificate

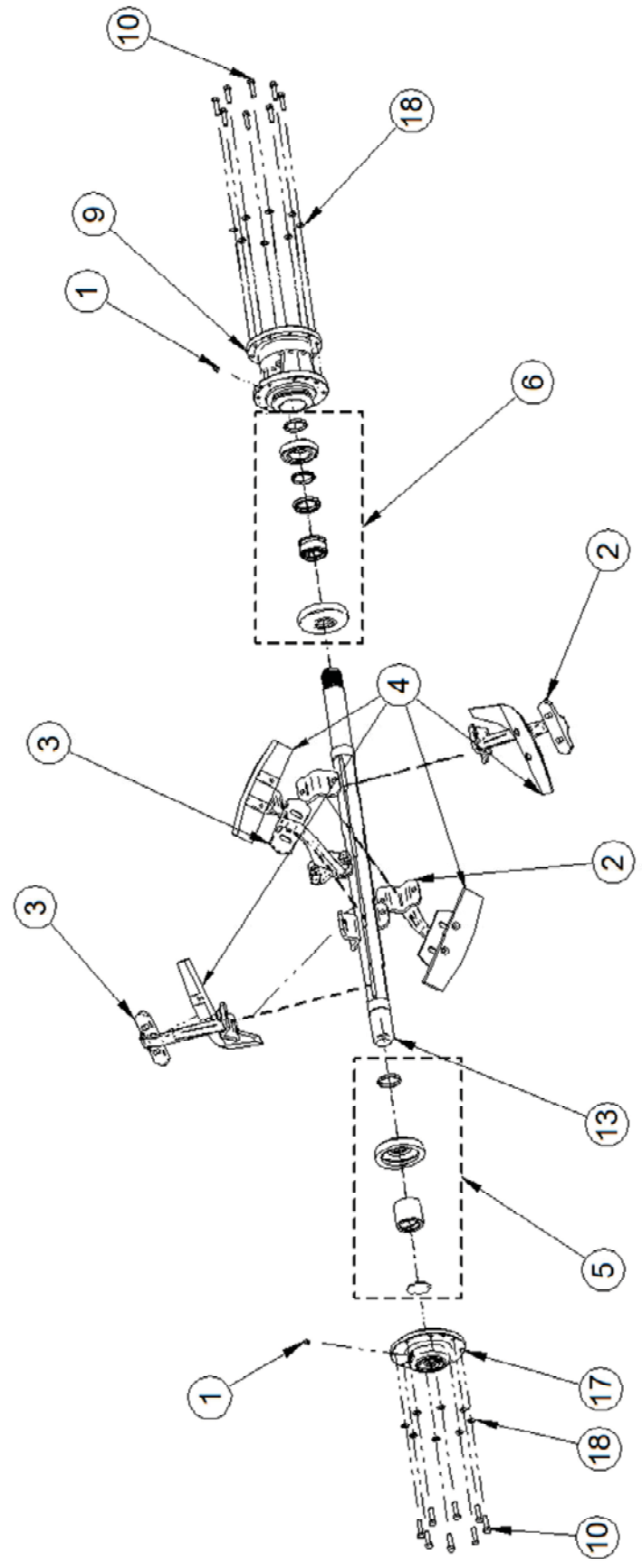

REF 2

Documentazione senza certificazione CE
Documentation without CE certificate

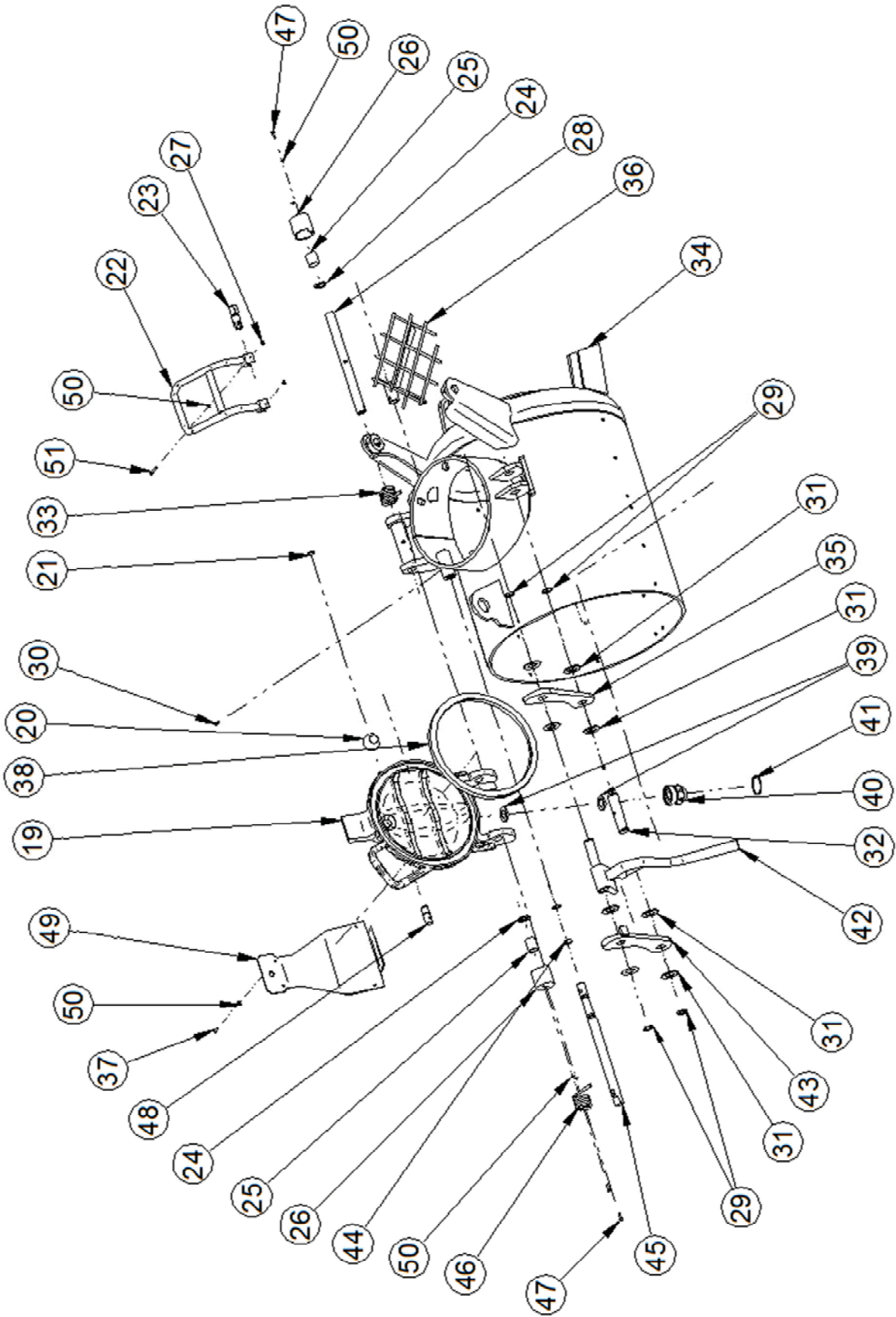

REF 3

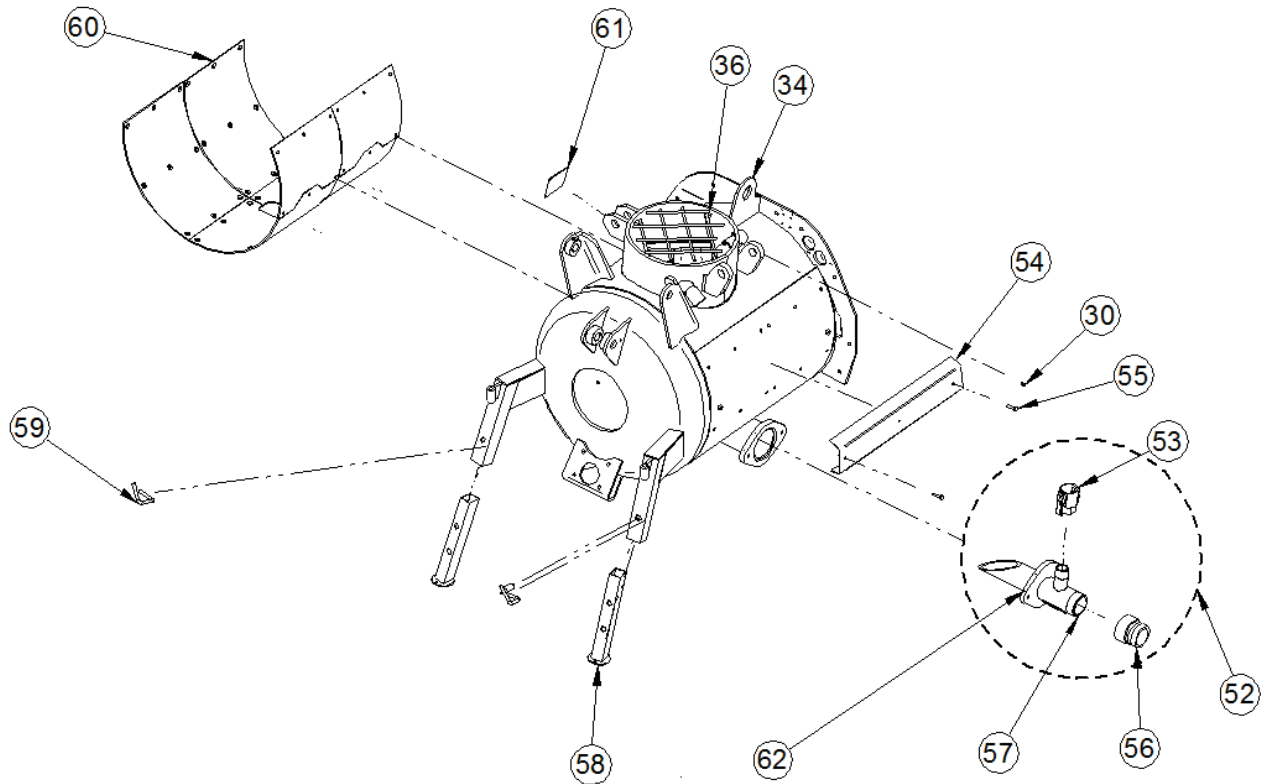

Ref.	Cod.	I	F	GB	D	E	Note
1	2230600	INGRASSAT.1/4 GAS 19 D.	GRAISSEUR 1/4 GAS 19 D.	LUBRICATOR 1/4 GAS 19 D.	SCHMIERBÜCHSE.1/4 GAS 19 D.	ENGRASAD.1/4 GAS 19 D.	
2	3235979	KIT BRACCETTO PALA SX MOVER 270 EVO	KIT BRAS PALE G MOVER 270 EVO	LH BLADE ARM KIT MOVER 270 EVO	SET SCHAUFELARM LINKS MOVER 270 EVO	KIT BRAZO PALA IZD.MOVER 270 EVO	
3	3235980	KIT BRACCETTO PALA DX MOVER 270 EVO	KIT BRAS PALE D MOVER 270 EVO	RH BLADE ARM KIT MOVER 270 EVO	SET SCHAUFELARM RECHTS MOVER 270 EVO	KIT BRAZO PALA DCH. MOVER 270 EVO	
4	1107062	KIT PALE DI MESCOLOMENTO SERB.270	KIT PALES MALAXEUSES RÉSERV. 270	MIXING BLADE KIT TANK 270	SET MISCHSCHAUFELN MISCHBEHÄLTER 270	KIT PALAS MEZCLADORAS DEP. 270	
5	3235966	KIT LATO CIECO	KIT CÔTÉ AVEUGLE	BLIND SIDE KIT	SET GESCHLOSSENE SEITE	KIT LADO CIEGO	
6	3235967	KIT LATO MOTORE	KIT CÔTÉ MOTEUR	ENGINE SIDE KIT	SET MOTORSEITE	KIT LADO MOTOR	
9	3229395	FLANGIA ZINCATA LATO RIDUTTORE MOVER	FLASQUE ZINGUÉE CÔTÉ RÉDUCTEUR MOVER	GALVANIZED FLANGE ON GEAR MOTOR SIDE MOVER	VERZINKTER FLANSCH SEITE GETRIEBEMOTOR MOVER	BRIDA GALVANIZADA LADO REDUCTOR MOVER	
10	2222050	VITE TE 8.8 5739 12X 45 Z	VIS TE 8.8 5739 12X 45 Z	HEX HEAD SCREW 8.8 5739 12X 45 Z	SCHRAUBE TE 8.8 5739 12X 45 Z	TORNILLO TE 8.8 5739 12X 45 Z	
13	3223755	ALBERO SERBATOIO 270 TRATTATO	ARBRE RÉSERVOIR 270 TRAITÉ	TANK SHAFT 270 TREATED	MISCHBEHÄLTERWELLE 270 BESCHICHTET	EJE DEPÓSITO 270 TRATADO	
17	3223757	FLANGIA ZINCATA LATO CIECO MOVER	FLASQUE ZINGUÉE CÔTÉ AVEUGLE MOVER	GALVANIZED FLANGE ON BLIND SIDE MOVER	VERZINKTER FLANSCH GESCHLOSSENE SEITE MOVER	BRIDA GALVANIZADA LADO CIEGO MOVER	
18	3211038	ROSETTA 6592 DIAM.13X24 Z	RONDILLE 6592 DIAM.13X24 Z	WASHER 6592 DIAM. 13X24 Z	U-SCHEIBE 6592 DRUCHM.13X24 Z	ARANDELA 6592 DIÁMETRO 13X24 Z	
19	3223771	BOCCAPORTO	ÉCOUTILLE	HATCH	DECKEL	BOCA	
20	3223787	VALVOLA A SFERA	SOUPAPE À BILLE	BALL VALVE	KUGELVENTIL	VÁLVULA DE ESFERA	
21	3224485	ANELLO OR 123	JOINT TORIQUE 123	O-RING 123	RING OR 123	ANILLO JUNTA TÓRICA 123	
22	3223775	MANIGLIA SFIATO SERBATOIO VERNICIATO	POIGNÉE ÉVENT RÉSERVOIR PEINT	PAINTED TANK VENT HANDLE	GRIFF MISCHBEHÄLTERENTLÜFTUNG LACKIERT	MANILLA PURGA DEPÓSITO PINTADO	
23	3223781	PERNO SFIATO DX	AXE ÉVENT D	RH VENT PIN	BOLZEN ENTLÜFTUNG RECHTS	PERNO PURGA DCH.	
24	3223956	DISTANZIALE	ENTRETOISE	SPACER	DISTANZSTÜCK	DISTANCIADOR	
25	3223921	BOCCOLA ALB. BOCCAPORTO 190-270	DOUILLE ARB. ÉCOUTILLE 190-270	SHAFT BUSHING HATCH 190-270	BUCHSE WELLE DECKEL 190-270	CASQUILLO EJ. BOCA 190-270	
26	3223784	COPERCHIO MOLLA SERBATOIO	COUVERCLE RESSORT RÉSERVOIR	TANK SPRING COVER	DECKEL FEDER MISCHBEHÄLTER	TAPA MUELLE DEPÓSITO	
27	3211470	DADO AUTOBLOC. M6 UNI7474 BASSO	ÉCROU DE SÛRETÉ M6 UNI7474 BAS	SELF-LOCKING NUT M6 UNI7474 LOW	SELBSTSICHERNDE MUTTER M6 UNI7474	TUERCA AUTOBLOC. M6 UNI7474 BAJA	
28	3223955	ALBERO BOCCAPORTO	ARBRE BOUCHE DE SORTIE	HATCH SHAFT	WELLE DECKEL	EJE BOCA DEPÓSITO	
29	2227240	ANELLO ARRESTO 7435 E/30	ANNEAU ARRÊT 7435 E/30	STOP RING 7435 E/30	ARRETIERRING 7435 E/30	ARO DE RETÉN 7435 E/30	
30	3223909	INGRASSATORE M6 DRITTO	GRAISSEUR M6 DROIT	LUBRICATOR M6 STRAIGHT	SCHMIERBÜCHSE M6 GERADE	ENGRASADOR M6 RECTO	
31	3236280	SPESSORE PERNO SERBATOIO	ÉPAISSEUR DE LA BOULE DE RÉSERVOIR	TANK BALL THICKNESS	TANKBALLSTÄRKE	ESPESSOR DE BOLA DE TANQUE	
32	3223953	PERNO ROTAZIONE	PIVOT ROTATION	ROTATION PIN	DREHBOLZEN	PERNO ROTACIÓN	
33	3223785	MOLLA C.ELI.TORS.DX	RESSORT C.HÉLIC.TORS.D	RH TORSION COIL SPRING	TORSIONSFEDER RECHTS	MUELLE C.ELI.TORS.DCH.	

Ref.	Cod.	I	F	GB	D	E	Note
34	3234404	SERBATOIO SALDATO 270 (USCITA DRIITA)	RÉSERVOIR SOUDÉ 270 (SORTIE DROITE)	WELDED TANK 270 (STRAIGHT OUTPUT)	GESCHWEISSTER MISCHBEHÄLTER 270 (GERADER AUSGANG)	DEPÓSITO SOLDADO 270 (SALIDA RECTA)	
35	3223954	LEVA DX CHIUSURA BOCCAPORTO	LEVIER D FERMETURE ÉCOUTILLE	RH HATCH CLOSING LEVER	HEBEL RECHTS DECKELVERSCHLUSS	PALANCA DCH. CIERRE BOCA	
36	3223801	GRIGLIA BOCCAPORTO VERNICIATA	GRILLE ÉCOUTILLE PEINTE	PAINTED HATCH GRILL	DECKELGITTER LACKIERT	REJILLA BOCA PINTADA	
37	2222002	VITE TE 5739 6X16 Z	VIS TE 5739 6X16 Z	HEX HEAD SCREW 5739 6X16 Z	SCHRAUBE TE 5739 6X16 Z	TORNILLO TE 5739 6X16 Z	
38	3223779	GUARNIZIONE BOCCAPORTO	JOINT ÉCOUTILLE	HATCH GASKET	DECKELDICHUNG	JUNTA BOCA	
39	3234681	GUARNIZIONE RACCORDO DI SFIATO MOVER	JOINT RACCORD ÉVENT MOVER	VENT FITTING GASKET MOVER	DICHTUNG ENTLÜFTUNGSANSCHLUSS MOVER	JUNTA RACOR DE PURGA MOVER	
40	3223788	RACCORDO SFIATO	RACCORD ÉVENT	VENT FITTING	ENTLÜFTUNGSANSCHLUSS	RACOR PURGA	
41	3226260	ANELLO OR 3225	JOINT TORIQUE 3225	O-RING 3225	RING OR 3225	ANILLO JUNTA TÓRICA 3225	
42	3223776	MANIGLIA DI CHIUSURA SERBATOIO VERNICIATA	POIGNÉE FERMETURE RÉSERVOIR PEINTE	PAINTED TANK CLOSING HANDLE	GRIFF MISCHBEHÄLTERVERSCHLUSS LACKIERT	MANILLA DE CIERRE DEPÓSITO PINTADO	
43	3233281	LEVA SX CHIUSURA BOCCAPORTO	LEVIER G FERMETURE ÉCOUTILLE	LH HATCH CLOSING LEVER	HEBEL LINKS DECKELVERSCHLUSS	PALANCA IZD. CIERRE BOCA	
44	3223956	DISTANZIALE	ENTRETOISE	SPACER	DISTANZSTÜCK	DISTANCIADOR	
45	3223817	PERNO ROTAZIONE RETE 270	AXE ROTATION RÉSEAU 270	NET ROTATION PIN 270	DREHBOLZEN GITTERNETZ 270	PERNO ROTACIÓN RED 270	
46	3223786	MOLLA ELIC. CIL TORS. SX	RESSORT HÉLIC. CIL TORS. G	COIL SPRING TORSION CYLINDER LH	TORSIONSFEDER LINKS	MUELLE HEL. CIL TORS. IZD.	
47	2222016	VITE TE 8.8 5739 6X 20 Z	VIS TE 8.8 5739 6X 20 Z	HEX HEAD SCREW 8.8 5739 6X 20 Z	SCHRAUBE TE 8.8 5739 6X 20 Z	TORNILLO TE 8.8 5739 6X 20 Z	
48	3223782	PERNO SFIATO SX	AXE ÉVENT G	LH VENT PIN	BOLZEN ENTLÜFTUNG LINKS	PERNO PURGA IZD.	
49	3223783	CONVOGLIATORE ARIA	CONVOYEUR AIR	AIR MANIFOLD	DRUCKLUFTFÖRDERER	CONDUCTO DE AIRE	
50	2224530	RONDELLA, UNI-6592, M 6 X12.5 IN ACCIAIO ZINCATO	RONDELLE, UNI-6592, M 6 X12.5 EN ACIER ZINGUÉ	WASHER, UNI-6592, M 6 X12.5 STAINLESS STEEL	U-SCHEIBE, UNI-6592, M 6 X12.5 AUS ZINKSTAHL	ARANDELA, UNI-6592, M 6 X12.5 DE ACERO GALVANIZADO	
51	2222013	VITE TE 8.8 5737 6X 40 Z	VIS TE 8.8 5737 6X 40 Z	HEX HEAD SCREW 8.8 5737 6X 40 Z	SCHRAUBE TE 8.8 5737 6X 40 Z	TORNILLO TE 8.8 5737 6X 40 Z	
52	3235965	"KIT COLLETTORE 2'''1/2 MOVER 270 EVO"	« KIT COLLECTEUR 2'''1/2 MOVER 270 EVO »	"MANIFOLD KIT 2'''1/2 MOVER 270 EVO"	„SET SAMMELLEITUNG 2'''1/2 MOVER 270 EVO"	"KIT COLECTOR 2'''1/2 MOVER 270 EVO"	
53	3224361	ATTACCO A CAMME DN35 M 1"1/4" G F	« ACCOUPLEMENT PAR CAMES DN 35 M 1''' 1/4''' G F »	"CAM COUPLING DN 35 M 1''' 1/4''' G F"	„NOCKENANSCHLUSS DN 35 M 1''' 1/4''' G F"	"CONEXIÓN DE LEVAS DN 35 M1''' 1/4''' G-F"	
54	3224840	LAMIERA PROTEZIONE TUBI	TÔLE PROTECTION TUYAUX	PIPES PROTECTION PLATE	SCHUTZBLECH SCHLÄUCHEE	CHAPA PROTECCIÓN TUBOS	
55	2222006	VITE TE, M M 8 X 30 Z	VIS TE, M M 8 X 30 Z	HEX HEAD SCREW, M M 8 X 30 Z	SCHRAUBE TE, M M 8 X 30 Z	TORNILLO TE, M M 8 X 30 Z	
56	3223819	"ATTACCO A CAMME DN 65 M- 2''' 1/2''' GF"	« ACCOUPLEMENT PAR CAMES DN 65 M- 2''' 1/2''' GF »	"CAM COUPLING DN 65 M- 2''' 1/2''' GF"	„NOCKENANSCHLUSS DN 65 M- 2''' 1/2''' GF"	"CONEXIÓN DE LEVAS DN 65 M- 2''' 1/2''' GF"	
57	3234412	"COLLET. USCITA MATER. 2'''-1/2 DRIITO SALD."	« COLLECT. SORTIE MATER. 2'''-1/2 DROIT SOUD. »	"MATERIAL OUTLET MANIFOLD 2'''-1/2 STRAIGHT WELDED"	„SAMMELLEITUNG MATERIALAUSGANG 2'''-1/2 GERADE GESCHWEISST"	"COLECT. SALIDA MATER. 2'''-1/2 RECTO SOLD."	
58	3223772	PIEDINO SERBATOIO	PIED RÉSERVOIR	TANK FOOT	STÜTZFUSS MISCHBEHÄLTER	PATA DEPÓSITO	
59	3224822	SPINA BLOCCAGGIO PIEDE	GOUJON D'ARRÊT PIED	FOOT LOCKING PIN	ARRETIERTSTIFT STÜTZFUSS	CLAVIJA BLOQUEO PATA	
60	1107212	KIT FASCE ANTIUSURA 270 (USCITA DRIITA)	KIT COLLIERS ANTI-USURE 270 (SORTIE DROITE)	ANTIWEAR BAND KIT 270 (STRAIGHT OUTLET)	SET VERSCHLEISSSCHUTZ-MANTEL 270 (GERADER AUSGANG)	KIT PLACAS ANTIDESGASTE 270 (SALIDA RECTA)	
61	3223777	TARGA OMOLOGAZIONE SERB.190-270	PLAQUE HOMOLOGATION RÉSERV. 190-270	TANK 190-270 APPROVAL PLATE	ZULASSUNGSSCHILD MISCHBEHÄLTER 190-270	PLACA HOMOLOGACIÓN DEP. 190-270	
62	3225169	ANELLO OR 8-4537 D.INTERNO 136.10	JOINT TORIQUE 8-4537 D. INTERNE 136.10	RING OR 8-4537 INNER DIAMETER 136.10	RING OR 8-4537 INNENDURCHM. 136.10	ANILLO JUNTA TÓRICA 8-4537 D. INTERNO 136.10	

Tab. 14 (Errore. L'origine riferimento non è stata trovata.)

Documentazione senza certificazione CE
Documentazione without CE certificate

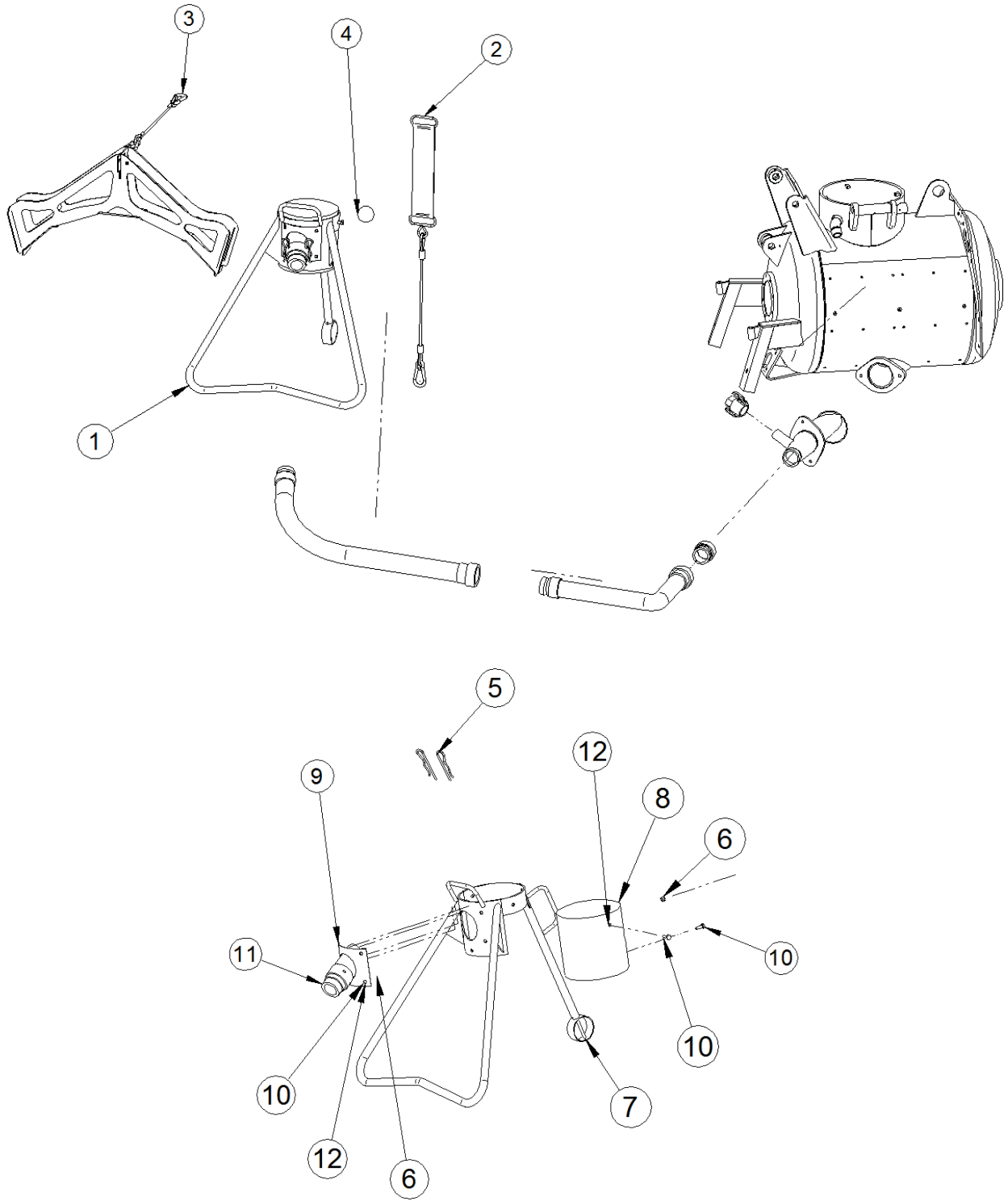

Fig. 19

Ref.	Cod.	I	F	GB	D	E	Note
1	3223897	"TREPPEDI COMPLETO ATTACCO 2 1/2"	« TRÉPIED COMPLET RACCORD 2 1/2 »	"TRIPOD STAND WITH 2 1/2" CONNECTION	„DREIFUSS KOMPLETT M. ANSCHLUSS 2 1/2"	"TRÍPODE CON CONEXIÓN 2 1/2"	
2	3223926	FASCIA REGGITUBO 190-270	COLLIER PORTE-TUYAU 190-270	PIPE HOLDER BAND 190-270	MANTEL SCHLAUCHHALTER 190- 270	BANDA ABRAZADERA TUBO 190- 270	
3	3223910	REGGITUBO IMER 190-270	PORTE-TUYAU IMER 190-270	PIPE HOLDER IMER 190-270	SCHLAUCHHALTER IMER 190-270	ABRAZADERA IMER 190-270	
4	1107522	KIT 10 PEZZI SPUGNA PER TUBO Ø 60	KIT 10 PIÈCES ÉPONGE POUR TUYAU Ø 60	KIT OF 10 PIECES OF SPONGE FOR PIPE Ø 60	10-TEILIGES SCHWAMM-SET FÜR SCHLAUCH Ø 60	KIT 10 UNIDADES ESPONJA PARA TUBO Ø 60	
5	3223903	COPIGLIA A MOLLA DOPPIO GIRO D.6	GOUPILLE À RESSORT DEUX TOURS D.6	SPRING COTTER PIN DOUBLE REVOLUTION D.6	FEDER-SPLINT DOPPELDREHUNG D.6	PASADOR CON MUELLE VUELTA DOBLE D.6	
6	2223920	DADO AUTOBLOCCANTE M10	ÉCROU AUTOBLOQUANT M10	SELF LOCKING NUT M10	SELBSTSICHERNDE MUTTER M10	TUERCA AUTOBLOCANTE M10	
7*	3223860	TELAIO TREPPEDI 190-270 VERNICIATO	CHÂSSIS TRÉPIED 190-270 PEINT	PAINTED TRIPOD FRAME 190-270	RAHMEN DREIFUSS 190-270 LACKIERT	BASTIDOR TRÍPODE 190-270 PINTADO	
8*	3223876	TUBO IN GOMMA KTR D.250X250	TUYAU EN CAOUTCHOUC KTR D.250X250	RUBBER PIPE KTR D.250X250	GUMMISCHLAUCH KTR D.250X250	TUBO DE GOMA KTR D.250X250	
9*	3223863	"ATTACCO TREPPEDI 2 1/2" VERNICIATO"	« RACCORD TRÉPIED 2 1/2" PEINT »	"PAINTED TRIPOD CONNECTION 2 1/2"	„ANSCHLUSS DREIFUSS 2 1/2" LACKIERT	"CONEXIÓN TRÍPODE 2 1/2" PINTADO"	
10*	2222146	VITE TE, M M 10 X 30 Z	VIS TE, M M 10 X 30 Z	HEX HEAD SCREW, M M 10 X 30 Z	SCHRAUBE TE, M M 10 X 30 Z	TORNILLO TE, M M 10 X 30 Z	
11	3223863	"TUBO ENTRATA MAT. 2" 190-270 VERN."	« TUYAU ENTRÉE MAT. 2" 190-270 PEINT »	"MATERIAL INTAKE PIPE 2" 190-270 PAINT."	„SCHLAUCH MATERIALEINGANG 2" 190-270 LACKIERT"	"TUBO ENTRADA MAT. 2" 190-270 PINT."	
12	2224260	ROSETTA 6593 D. 10x30 Z	RONDELLE 6593 D. 10x30 Z	WASHER 6593 D. 10x30 Z	U-SCHEIBE 6593 D.10x30 Z	ARANDELA 6593 D. 10x30 Z	

Tab. 15 (Fig. 19)

KIT 1107047

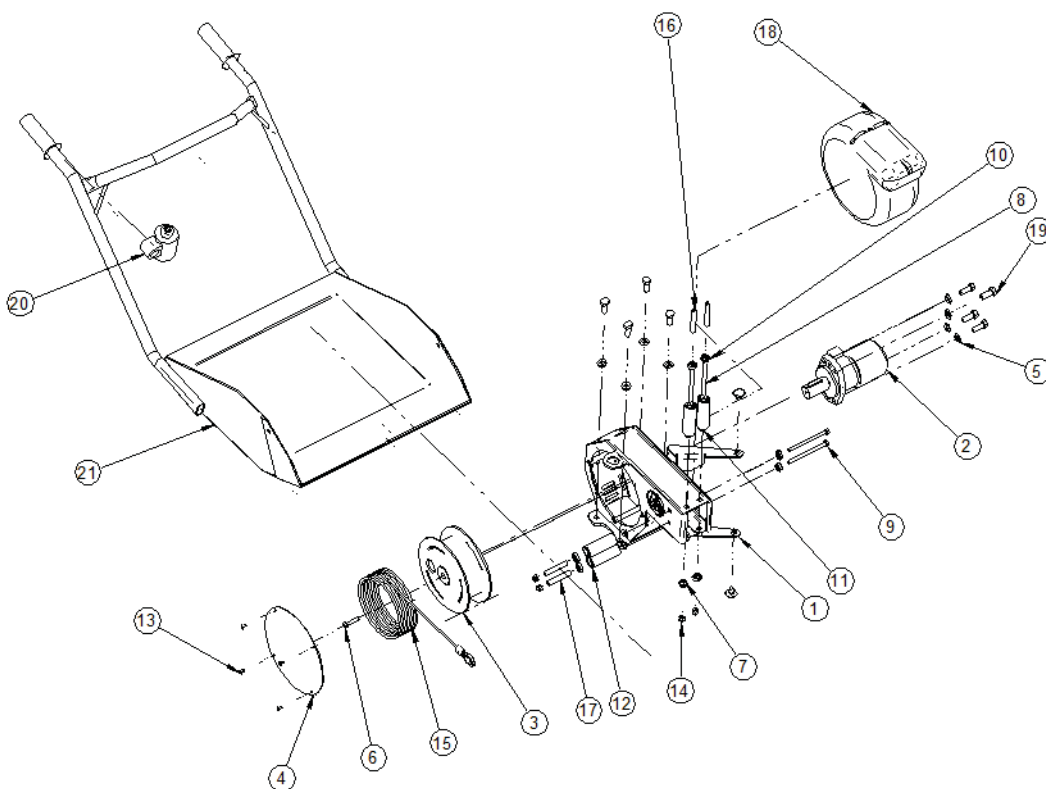

Fig. 20

Ref.	Cod.	I	F	GB	D	E	Note
1	3223875	TELAIO SUPPORTO TAMBURO 190-270	CHÂSSIS SUPPORT TAMBOUR 190-270	DRUM SUPPORT FRAME 190-270	STÜTZRAHMEN TROMMEL 190-270	BASTIDOR SOPORTE TAMBOR 190-270	
2	3223893	MOTORE IDRAULICO	MOTEUR HYDRAULIQUE	HYDRAULIC MOTOR	HYDRAULIKMOTOR	MOTOR HIDRÁULICO	
3	3223874	TAMBURO ZINCATO 190-270	TAMBOUR ZINGUÉ 190-270	GALVANIZED DRUM 190-270	VERZINKTE TROMMEL 190-270	TAMBOR GALVANIZADO 190-270	
4	3223878	COPERCHIO SUPPORTO	COUVERCLE SUPPORT	SUPPORT COVER	DECKEL HALTERUNG	TAPA SOPORTE	
5	2224380	ROSETTA 6592 D.12x25 Z	RONDELLE 6592 D.12x25 Z	WASHER 6592 D.12x25 Z	U-SCHEIBE 6592 D.12x25 Z	ARANDELA 6592 D.12x25 Z	
6	2222530	VITE TCEI 5931 8X 35 Z	VIS TCEI 5931 8X 35 Z	HEX SOCKET HEAD CAP SCREW 5931 8X 35 Z	SCHRAUBE TCEI 5931 8X 35 Z	TORNILLO TCEI 5931 8X 35 Z	
7	3223887	BOCCOLA D=20 ZINCATA	DOUILLE D=20 ZINGUÉE	GALVANIZED BUSHING D=20	BUCHSE D=20 VERINKT	CASQUILLO D=20 GALVANIZADO	
8	3206601	VITE TE 8.8 5737 8X120 Z	VIS TE 8.8 5737 8X120 Z	HEX HEAD SCREW 8.8 5737 8X120 Z	SCHRAUBE TE 8.8 5737 8X120 Z	TORNILLO TE 8.8 5737 8X120 Z	
9	2222068	VITE TE 8.8 5737 8X110 Z	VIS TE 8.8 5737 8X110 Z	HEX HEAD SCREW 8.8 5737 8X110 Z	SCHRAUBE TE 8.8 5737 8X110 Z	TORNILLO TE 8.8 5737 8X110 Z	
10	3204945	CUSCINETTO 608 2RSH	PALIER 608 2RSH	BEARING 608 2RSH	LAGER 608 2RSH	COJINETE 608 2RSH	
11	3223885	RULLINO VERTICALE TRATTATO	ROULEAU VERTICAL TRAITÉ	TREATED VERTICAL ROLLER	VERTIKALE WALZE BESCHICHTET	RODILLO VERTICAL TRATADO	
12	3223886	RULLINO ORIZZONTALE TRATTATO	ROULEAU HORIZONTAL TRAITÉ	TREATED HORIZONTAL ROLLER	HORIZONTALE WALZE BESCHICHTET	RODILLO HORIZONTAL TRATADO	
13	3203921	VITE TRILOBATA TC PH M5x10 N	VIS TRILOBÉE TC PH M5x10 N	CYLINDRICAL HEAD THREE-LOBED SCREW PH M5x10 N	GESTAUCHTE SCHRAUBE TC PH M5x10 N	TORNILLO TRILOBULADO TC PH M5x10 N	
14	2223923	DADO AUTOBLOC. M.8 UNI 7473	ÉCROU DE SÛRETÉ M.8 UNI 7473	SELF-LOCKING NUT M.8 UNI 7473	SELBSTSICHERNDE MUTTER M.8 UNI 7473	TUERCA AUTOBLOC. M.8 UNI 7473	
15	3225167	FUNE COMPLETA PER AVVOLGICAVO MOVER	CÂBLE COMPLET POUR ENROULEUR MOVER	COMPLETE WIRE FOR CABLE WINDER MOVER	KOMPLETTES SEIL FÜR KABELROLLE MOVER	CABLE COMPLETO PARA ENROLLADOR CABLE MOVER	
16*	3224735	DISTANZIALE CUSCINETTO L=75	ENTRETOISE PALIER L=75	BEARING SPACER L=75	DISTANZSTÜCK LAGER L=75	DISTANCIADOR COJINETE L=75	
17	3224862	DISTANZIALE CUSCINETTO L=65 ZINCATO	ENTRETOISE PALIER L=65 ZINGUÉ	BEARING SPACER L=65 GALVANIZED	DISTANZSTÜCK LAGER L=65 GALVANIZT	DISTANCIADOR COJINETE L=65 GALVANIZADO	
18	3227674	AVVOLGICAVO NERO SERIE XF 14 MT	ENROULEUR NOIR SÉRIE XF 14 M	BLACK CABLE WINDER SERIES XF 14 MT	KABELROLLE SCHWARZ SERIE XF 14 MT	ENROLLADOR CABLE NEGRO SERIE XF 14 M	
19	2222181	VITE TE 8.8 5739 12X 30 Z	VIS TE 8.8 5739 12X 30 Z	HEX HEAD SCREW 8.8 5739 12X 30 Z	SCHRAUBE TE 8.8 5739 12X 30 Z	TORNILLO TE 8.8 5739 12X 30 Z	
20	3227711	PULSAN.PER PALA TER A.402	BOUT. POUR PALE TER A.402	BUTTON FOR BLADE TER A.402	TASTE FÜR SCHAUFEL TER A.402	PULS. PARA PALA A.402	
21	3223935	BADILE	PELLE	SHOVEL	SCHAUFEL	PALA	

Tab. 16

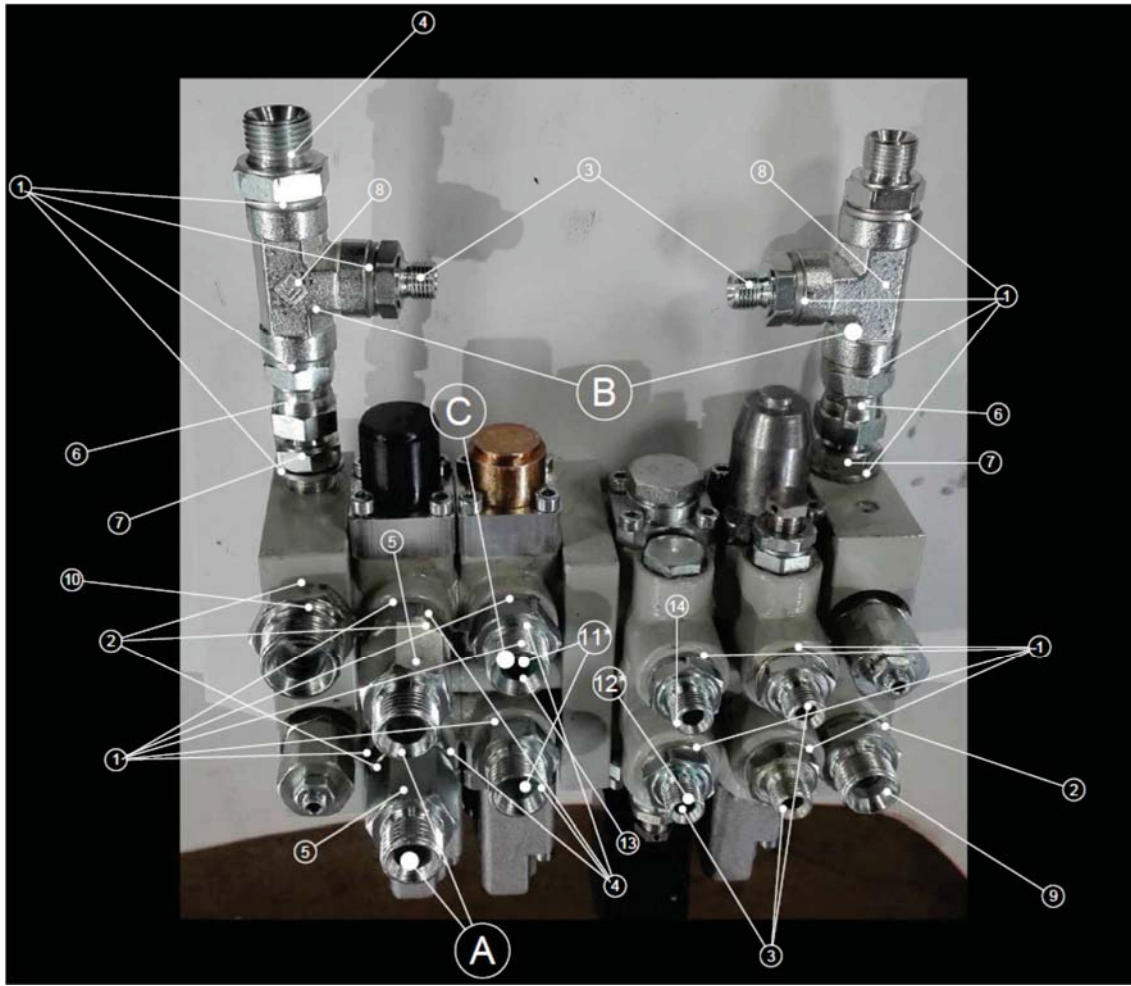

Fig. 22

Ref.	Cod.	I	F	GB	D	E	Note
1	3251846	RONDELLA GM AUTOCENTRANTE 3/8"	RONDELLE GM AUTOCENTRANTE 3/8"	SELF-CENTERING WASHER GM 3/8"	SELBSTZENTRIERENDE GM-USCHEIBE 3/8"	ARANDELA GM AUTOCENTRANTE 3/8"	
2	1220140	RONDELLA GM AUTOCENTRANTE 1/2"	RONDELLE GM AUTOCENTRANTE 1/2"	SELF-CENTERING WASHER GM 1/2"	SELBSTZENTRIERENDE GM-USCHEIBE 1/2"	ARANDELA GM AUTOCENTRANTE 1/2"	
3	3225124	NIPLES OLEOD.RIDOT.CILIN.3/8"-1/4"	NIPLES HYDRAUL. RÉDUIT CYLIN. 3/8"-1/4"	CYLINDER HYDRAULIC REDUCTION NIPPLES 3/8"-1/4"	NIPPEL HYDR. REDUZIERSTÜCK ZYL. 3/8"-1/4"	NIPLES HIDR.REDUCT.CILIN.3/8"-1/4"	
4	3225154	NIPLES OLEOD.RIDOT.1/2"-3/8" CILIN.	NIPLES HYDRAUL. RÉDUIT 1/2"-3/8" CYLIN.	CYLINDER HYDRAULIC REDUCTION NIPPLES 1/2"-3/8"	NIPPEL HYDR. REDUZIERSTÜCK 1/2"-3/8" ZYL.	NIPLES HIDR.REDUCT.1/2"-3/8" CILIN.	
5	3225599	PROLUNGA OLEOD. M.F. 1/2" L.25 MM	RALLONGE HYDRAUL. M.F. 1/2" L.25 MM	HYDRAULIC EXTENSION M.F. 1/2" L.25 MM	VERLÄNGERUNGSKABEL HYDR. S.B. 1/2" L.25 MM	PROLONGACIÓN HIDR. M.H. 1/2" L.25 MM	
6	3225694	ADATTATORE OLEODINAMICO 3/8" M.F	ADAPTATEUR HYDRAULIQUE 3/8" M.F	HYDRAULIC ADAPTER 3/8" M.F	PASSSTÜCK HYDR. 3/8" S.B.	ADAPTADOR HIDRÁULICO 3/8" M.H	
7	3225153	NIPLES OLEODINAMICO 3/8" CIL.SV60°	NIPLES HYDRAULIQUE 3/8" CYL.SV60°	HYDRAULIC NIPPLES 3/8" CYL.SV60°	NIPPEL HYDR. 3/8" ZYL.SV60°	NIPLES HIDRÁULICO 3/8" CIL.SV60°	
8	3225156	RACCORD.OLEODINAMICO T F.F.F. 3/8"	RACCORD HYDRAULIQUE T F.F.F. 3/8"	HYDRAULIC FITTING T F.F.F. 3/8"	HYDR. KUPPLUNG T F.F.F. 3/8"	RACOR HIDRÁULICO T F.F.F. 3/8"	
9	3225152	NIPLES OLEODINAMICO 1/2" CIL.SV60°	NIPLES HYDRAULIQUE 1/2" CYL.SV60°	HYDRAULIC NIPPLES 1/2" CYL.SV60°	NIPPEL HYDR. 1/2" ZYL.SV60°	NIPLES HIDRÁULICO 1/2" CIL.SV60°	
10	3225161	NIPLES OLEOD.RID.3/4"-1/2" CILIND.	NIPLES HYDRAUL. RÉD. 3/4"-1/2" CYLIND.	CYLINDER HYDRAULIC REDUCTION NIPPLES 3/4"-1/2"	NIPPEL HYDR. REDUZIERSTÜCK 1/4"-1/2" ZYL.	NIPLES HIDR.REDUCT.3/4"-1/2" CILIN.	
11	3226394	TAPPO OLEOD. F. GIREVOLE 1/2"	BOUCHON HYDR. F. PIVOTANT 1/2"	HYDRAULIC PLUG F. SWIVEL 1/2"	HYDR. VERSCHLUSS F. SCHWENKBAR 1/2"	TAPÓN HIDR. F. GIRATORIO 1/2"	
12	3225638	TAPPO OLEOD. F. GIREVOLE 1/4"	BOUCHON HYDR. F. PIVOTANT 1/4"	HYDRAULIC PLUG F. SWIVEL 1/4"	HYDR. VERSCHLUSS F. SCHWENKBAR 1/4"	TAPÓN HIDR. F. GIRATORIO 1/4"	
13	3225695	PROLUNGA OLEOD. M.F. 1/2" L.45 MM	RALLONGE HYDRAUL. M.F. 1/2" L.45 MM	HYDRAULIC EXTENSION M.F. 1/2" L.45 MM	VERLÄNGERUNGSKABEL HYDR. S.B. 1/2" L.45 MM	PROLONGACIÓN HIDR. M.H. 1/2" L.45 MM	
14	3225160	TAPPO OLEODINAMICO M.3/8" ESAGONALE	BOUCHON HYDRAULIQUE M.3/8" HEXAGONAL	HEXAGONAL HYDRAULIC PLUG M.3/8"	HYDR. SECHSKANTVERSCHLUSS M.3/8"	TAPÓN HIDRÁULICO M.3/8" HEXAGONAL	

Tab. 17 (Fig. 22)

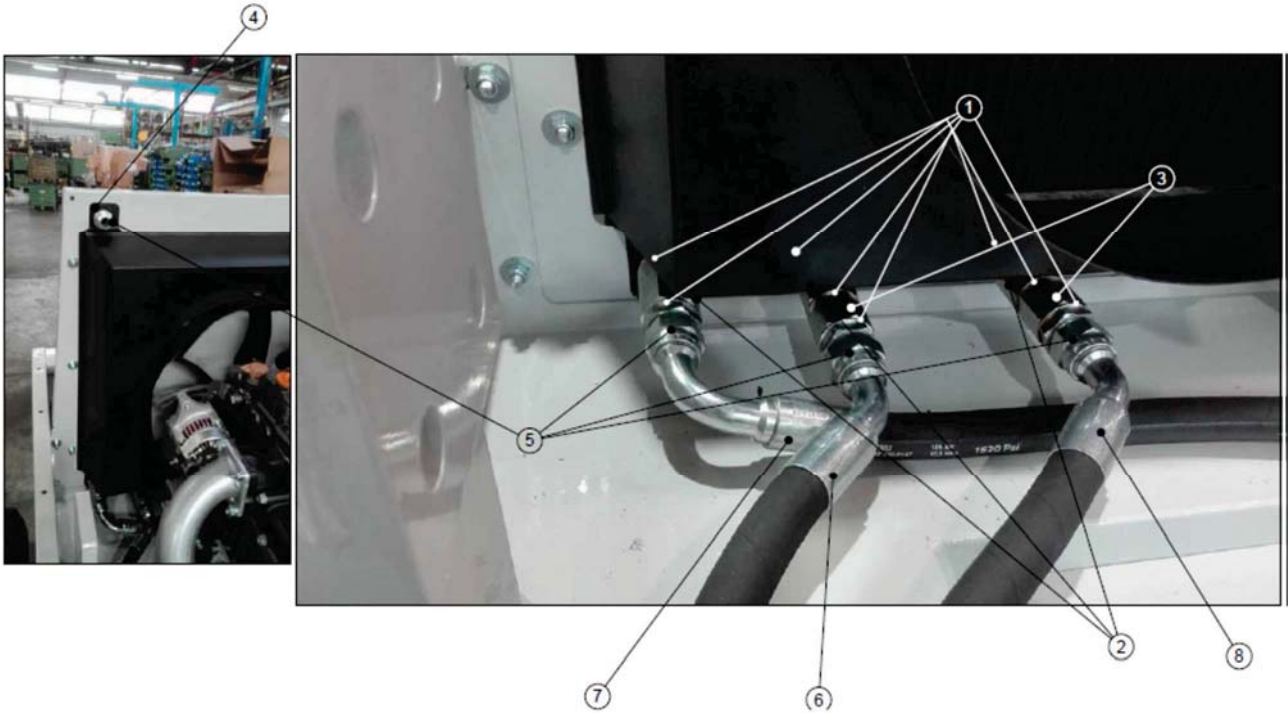

Fig. 23

Ref.	Cod.	I	F	GB	D	E	Note
1	3225165	RONDELLA GM AUTOCENTRANTE 3/4"	RONDELLE GM AUTOCENTRANTE 3/4"	SELF-CENTERING WASHER GM 3/4"	SELBSTZENTRIERENDE GM-U-SCHEIBE 3/4"	ARANDELA GM AUTOCENTRANTE 3/4"	
2	3229305	PROLUNGA OLEOD. M.F. 3/4" L60 SV60°	RALLONGE HYDRAUL. M.F. 3/4" L60 SV60°	HYDRAULIC EXTENSION M.F. 3/4" L60 SV60°	VERLÄNGERUNGSKABEL HYDR. S.B. 3/4" L60 SV60°	PROLONGACIÓN HIDR. M.H. 3/4" L60 SV60°	
3	3225633	PROLUNGA OLEOD. M.F. 3/4" L.30 MM	RALLONGE HYDRAUL. M.F. 3/4" L.30 MM	HYDRAULIC EXTENSION M.F. 3/4" L.30 MM	VERLÄNGERUNGSKABEL HYDR. S.B. 3/4" L.30 MM	PROLONGACIÓN HIDR. M.H. 3/4" L.30 MM	
4	3225165	RONDELLA GM AUTOCENTRANTE 3/4"	RONDELLE GM AUTOCENTRANTE 3/4"	SELF-CENTERING WASHER GM 3/4"	SELBSTZENTRIERENDE GM-U-SCHEIBE 3/4"	ARANDELA GM AUTOCENTRANTE 3/4"	
5	3225620	NIPLES OLEOD.CILINDRICO 3/4" SV60°	NIPLES HYDR. CYLINDRIQUE 3/4" SV60°	CYLINDRICAL HYDRAULIC NIPPLES 3/4" SV60°	NIPPEL HYDR. ZYL. 3/4" SV60°	NIPLES HIDR. CILIN. 3/4" SV60°	
6	3235838	TUBO 2 L=1470 MM	TUBE 2 L=1470 MM	PIPE 2 L=1470 MM	SCHLAUCH 2 L=1470 MM	TUBO 2 L=1470 MM	
7	3235845	TUBO 9 L=1120 MM	TUBE 9 L=1120 MM	PIPE 9 L=1120 MM	SCHLAUCH 9 L=1120 MM	TUBO 9 L=1120 MM	
8	3235837	TTUBO 1 L=1470 MM	TUBE 1 L=1470 MM	PIPE 1 L=1470 MM	SCHLAUCH 1 L=1470 MM	TUBO 1 L=1470 MM	

Tab. 18 (Fig. 23)



Figura 24

REF. A						
Cod.	I	F	GB	D	E	Note
3225600	TUBO. 2X5mm L.600	TUBE 2X5mm L.600	TUBE 2X5mm L.600	ROHR 2X5mm L.600	TUBO 2X5mm L.600	
3225124	NIPLES.3/8"-1/4"	NIPLES.3/8"-1/4"	NIPLES.3/8"-1/4"	NIPLES.3/8"-1/4"	NIPLES.3/8"-1/4"	
3251846	RONDELLA 3/8"	RONDELLE 3/8"	WASHER 3/8"	SCHEIBE 3/8"	ARANDELLA 3/8"	
3235853	TUBO 20 L=1940 MM 3/8"	TUBE 20 L=1940 MM 3/8"	TUBE 20 L=1940 MM 3/8"	ROHR 20 L=1940 MM 3/8"	TUBO 20 L=1940 MM 3/8"	
3225153	NIPLES 3/8"	NIPLES 3/8"	NIPLES 3/8"	NIPLES 3/8"	NIPLES 3/8"	
3251846	RONDELLA 3/8"	RONDELLE 3/8"	WASHER 3/8"	SCHEIBE 3/8"	ARANDELLA 3/8"	
3225156	RACCORDO 3/8" F.F.F.	JONCTION 3/8" F.F.F.	JUNCTION 3/8 F.F.F.	KREUZUNG 3/8 F.F.F.	UNION 3/8 F.F.F.	
3251846	RONDELLA 3/8"	RONDELLE 3/8"	WASHER 3/8"	SCHEIBE 3/8"	ARANDELLA 3/8"	
3225694	RACCORDO 3/8" M.F"	JONCTION 3/8" MF	JUNCTION 3/8 MF	KREUZUNG 3/8 MF	UNION 3/8" MF	
3225153	NIPLES 3/8"	NIPLES 3/8"	NIPLES 3/8"	NIPLES 3/8"	NIPLES 3/8"	
3251846	RONDELLA 3/8"	RONDELLE 3/8"	WASHER 3/8"	SCHEIBE 3/8"	ARANDELLA 3/8"	

Tabella 19

REF. B						
Cod.	I	F	GB	D	E	Note
3225600	TUBO. 2X5mm L.600	TUBE 2X5mm L.600	TUBE 2X5mm L.600	ROHR 2X5mm L.600	TUBO 2X5mm L.600	
3225157	CURVA 90°MF 1/4"	COURBE 90°MF 1/4"	CURVE 90°MF 1/4"	KURVE 90°MF 1/4"	CURVA 90°MF 1/4"	
3225124	NIPLES.3/8"-1/4"	NIPLES.3/8"-1/4"	NIPLES.3/8"-1/4"	NIPLES.3/8"-1/4"	NIPLES.3/8"-1/4"	
3251846	RONDELLA 3/8"	RONDELLE 3/8"	WASHER 3/8"	SCHEIBE 3/8"	ARANDELLA 3/8"	
3235852	TUBO 19 L=1900 MM 1/2"	TUBE 19 L=1900 MM 1/2"	TUBE 19 L=1900 MM 1/2"	ROHR 19 L=1900 MM 1/2"	TUBO 19 L=1900 MM 1/2"	
3225154	NIPLES.1/2"-3/8"	NIPLES.1/2"-3/8"	NIPLES.1/2"-3/8"	NIPLES.1/2"-3/8"	NIPLES.1/2"-3/8"	
3251846	RONDELLA 3/8"	RONDELLE 3/8"	WASHER 3/8"	SCHEIBE 3/8"	ARANDELLA 3/8"	
3225156	RACCORDO 3/8" F.F.F.	JONCTION 3/8" F.F.F.	JUNCTION 3/8 F.F.F.	KREUZUNG 3/8 F.F.F.	UNION 3/8 F.F.F.	
3251846	RONDELLA 3/8"	RONDELLE 3/8"	WASHER 3/8"	SCHEIBE 3/8"	ARANDELLA 3/8"	
3225694	RACCORDO 3/8" M.F"	JONCTION 3/8" MF	JUNCTION 3/8 MF	KREUZUNG 3/8 MF	UNION 3/8" MF	
3225153	NIPLES 3/8"	NIPLES 3/8"	NIPLES 3/8"	NIPLES 3/8"	NIPLES 3/8"	
3251846	RONDELLA 3/8"	RONDELLE 3/8"	WASHER 3/8"	SCHEIBE 3/8"	ARANDELLA 3/8"	

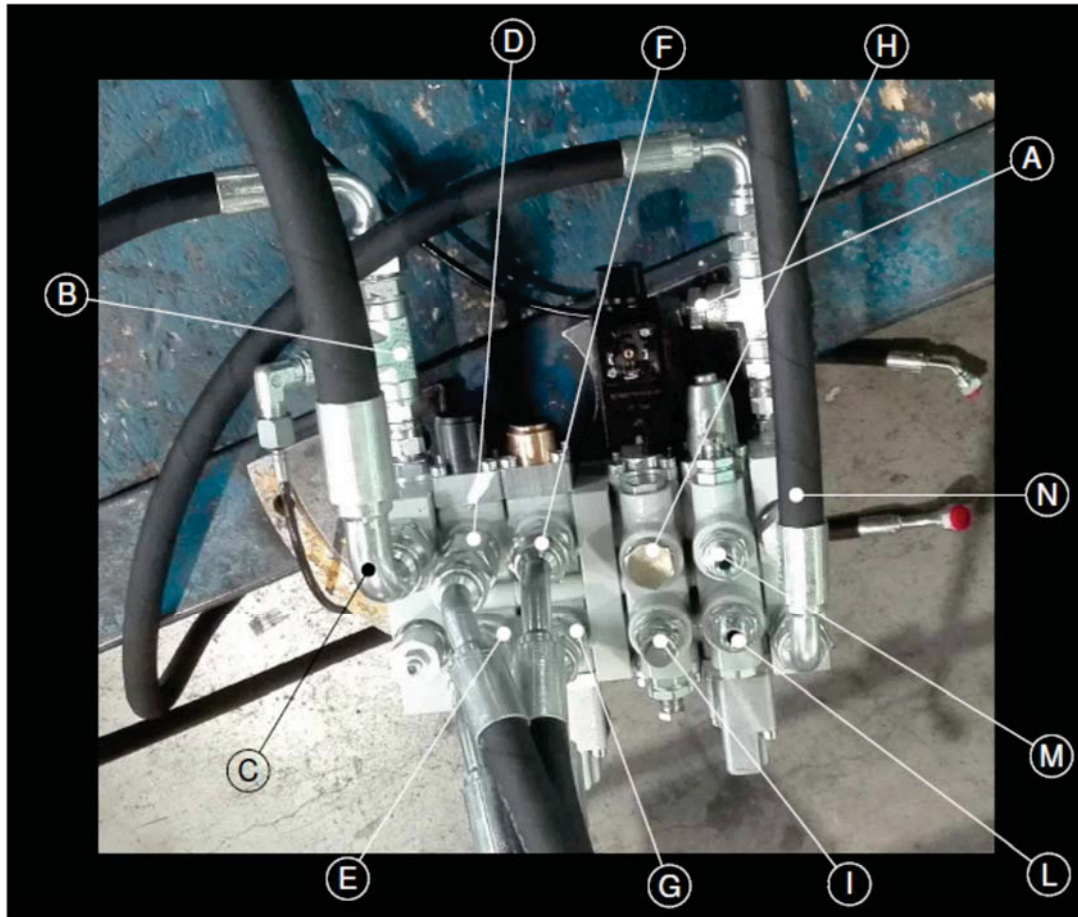
Tabella 20

REF. C						
Cod.	I	F	GB	D	E	Note
3235846	TUBO 4 L=2260 MM 3/4	TUBE 4 L=2260 MM 3/4	TUBE4 L=2260 MM 3/4	ROHR 4 L=2260 MM 3/4	TUBO 4 L=2260 MM 3/4	
3225161	NIPLES 3/4"-1/2"	NIPLES 3/4"-1/2"	NIPLES 3/4"-1/2"	NIPLES 3/4"-1/2"	NIPLES 3/4"-1/2"	
1220140	RONDELLA 1/2"	RONDELLE 1/2"	WASHER 1/2"	SCHEIBE 1/2"	ARANDELLA 1/2"	

Tabella 21

REF. D						
Cod.	I	F	GB	D	E	Note
3235848	TUBO 12 L=390 MM 1/2	TUBE 12 L=390 MM 1/2	TUBE 12 L=390 MM 1/2	ROHR 12 L=390 MM 1/2	TUBO 12 L=390 MM 1/2	
3225599	PROLUNGA M.F. 1/2	EXTENSION M.F. 1/2	EXTENSION M.F. 1/2	ERWEITERUNG M.F. 1/2	EXTENSION M.F. 1/2	
1220140	RONDELLA 1/2"	RONDELLE 1/2"	WASHER 1/2"	SCHEIBE 1/2"	ARANDELLA 1/2"	
3225154	NIPLES.1/2"-3/8"	NIPLES.1/2"-3/8"	NIPLES.1/2"-3/8"	NIPLES.1/2"-3/8"	NIPLES.1/2"-3/8"	
3251846	RONDELLA 3/8"	RONDELLE 3/8"	WASHER 3/8"	SCHEIBE 3/8"	ARANDELLA 3/8"	

Tabella 22

REF. E						
Cod.	I	F	GB	D	E	Note
3235847	TUBO 11 L=625 MM 1/2"	TUBE 11 L=625 MM 1/2"	TUBE 11 L=625 MM 1/2"	ROHR 11 L=625 MM 1/2"	TUBO 11 L=625 MM 1/2"	
3225599	PROLUNGA M.F. 1/2	EXTENSION M.F. 1/2	EXTENSION M.F. 1/2	ERWEITERUNG M.F. 1/2	EXTENSION M.F. 1/2	
1220140	RONDELLA 1/2"	RONDELLE 1/2"	WASHER 1/2"	SCHEIBE 1/2"	ARANDELLA 1/2"	
3225154	NIPLES.1/2"-3/8"	NIPLES.1/2"-3/8"	NIPLES.1/2"-3/8"	NIPLES.1/2"-3/8"	NIPLES.1/2"-3/8"	
3251846	RONDELLA 3/8"	RONDELLE 3/8"	WASHER 3/8"	SCHEIBE 3/8"	ARANDELLA 3/8"	

Tabella 23

REF. F						
Cod.	I	F	GB	D	E	Note
3235850	TUBO 14 L=800 MM 1/2"	TUBE 14 L=800 MM 1/2"	TUBE 14 L=800 MM 1/2"	ROHR 14 L=800 MM 1/2"	TUBO 14 L=800 MM 1/2"	
3225154	NIPLES.1/2"-3/8"	NIPLES.1/2"-3/8"	NIPLES.1/2"-3/8"	NIPLES.1/2"-3/8"	NIPLES.1/2"-3/8"	
3251846	RONDELLA 3/8"	RONDELLE 3/8"	WASHER 3/8"	SCHEIBE 3/8"	ARANDELLA 3/8"	

Tabella 24

REF. G						
Cod.	I	F	GB	D	E	Note
3235850	TUBO "13 L=850 MM 1/2"	TUBE "13 L=850 MM 1/2"	TUBE "13 L=850 MM 1/2"	ROHR "13 L=850 MM 1/2"	TUBO "13 L=850 MM 1/2"	
3225154	NIPLES.1/2"-3/8"	NIPLES.1/2"-3/8"	NIPLES.1/2"-3/8"	NIPLES.1/2"-3/8"	NIPLES.1/2"-3/8"	
3251846	RONDELLA 3/8"	RONDELLE 3/8"	WASHER 3/8"	SCHEIBE 3/8"	ARANDELLA 3/8"	

Tabella 25

REF. H						
Cod.	I	F	GB	D	E	Note
3225160	TAPPO M.3/8"	BOUCHON M.3/8"	CAP M.3/8"	STOPPER M.3/8"	TAPON M.3/8"	
3251846	RONDELLA 3/8"	RONDELLE 3/8"	WASHER 3/8"	SCHEIBE 3/8"	ARANDELLA 3/8"	

Tabella 26

REF. I						
Cod.	I	F	GB	D	E	Note
3235856	TUBO 23 L=3060 MM 1/4"	TUBE 23 L=3060 MM 1/4"	TUBE 23 L=3060 MM 1/4"	TUBE 23 L=3060 MM 1/4"	TUBE 23 L=3060 MM 1/4"	
3225124	NIPLES.3/8"-1/4"	NIPLES.3/8"-1/4"	NIPLES.3/8"-1/4"	NIPLES.3/8"-1/4"	NIPLES.3/8"-1/4"	
3251846	RONDELLA 3/8"	RONDELLE 3/8"	WASHER 3/8"	SCHEIBE 3/8"	ARANDELLA 3/8"	

Tabella 27

REF. L						
Cod.	I	F	GB	D	E	Note
3225145	TUBO " 1/4"L.2110"	TUBE 1/4"L.2110"	TUBE 1/4"L.2110"	TUBE " 1/4"L.2110"	TUBO " 1/4"L.2110"	
3225124	NIPLES.3/8"-1/4"	NIPLES.3/8"-1/4"	NIPLES.3/8"-1/4"	NIPLES.3/8"-1/4"	NIPLES.3/8"-1/4"	
3251846	RONDELLA 3/8"	RONDELLE 3/8"	WASHER 3/8"	SCHEIBE 3/8"	ARANDELLA 3/8"	

Tabella 28

REF. M						
Cod.	I	F	GB	D	E	Note
3225145	TUBO " 1/4"L.2110"	TUBE 1/4"L.2110"	TUBE 1/4"L.2110"	TUBE " 1/4"L.2110"	TUBO " 1/4"L.2110"	
3225124	NIPLES.3/8"-1/4"	NIPLES.3/8"-1/4"	NIPLES.3/8"-1/4"	NIPLES.3/8"-1/4"	NIPLES.3/8"-1/4"	
3251846	RONDELLA 3/8"	RONDELLE 3/8"	WASHER 3/8"	SCHEIBE 3/8"	ARANDELLA 3/8"	

Tabella 29



Figura 26

Ref.	Cod.	I	F	GB	D	E	Note
1	3236496	KIT VALVOLA	KIT DE VALVE	KIT INTAKE VALVE	VENTILKIT	KIT DE VALVULA	
K1	3236026	KIT M32-M39	KIT M32-M39	KIT M32-M39	KIT M32-M39	KIT M32-M39	
K14	3236027	KIT G35-36	KIT G35-36	KIT G35-36	KIT G35-36	KIT G35-36	
K15	3236028	VISORE OLIO VRO19	VIEWER VRO19	VIEWER VRO19	ZUSCHAUER VRO19	ESPECTADOR VRO19	
K16	3236029	KIT RACCORDI	KIT JONCTION"	KIT JUNCTION	KIT KREUZUNG	KIT UNION	
K17	3236030	KIT RICAMBI	KIT RECHANGE	KIT SPARE PARTS	KIT ERSATZTEILLE	KIT REFACIONES	
K18	3236031	KIT ANELLI TENUTA	KIT BAGUES D'ETANCHEITE	KIT SEALED RINGS	KIT DICHRINGE	KIT ANILLOS DE SELLADO	

Tabella 30 (Figura 26)

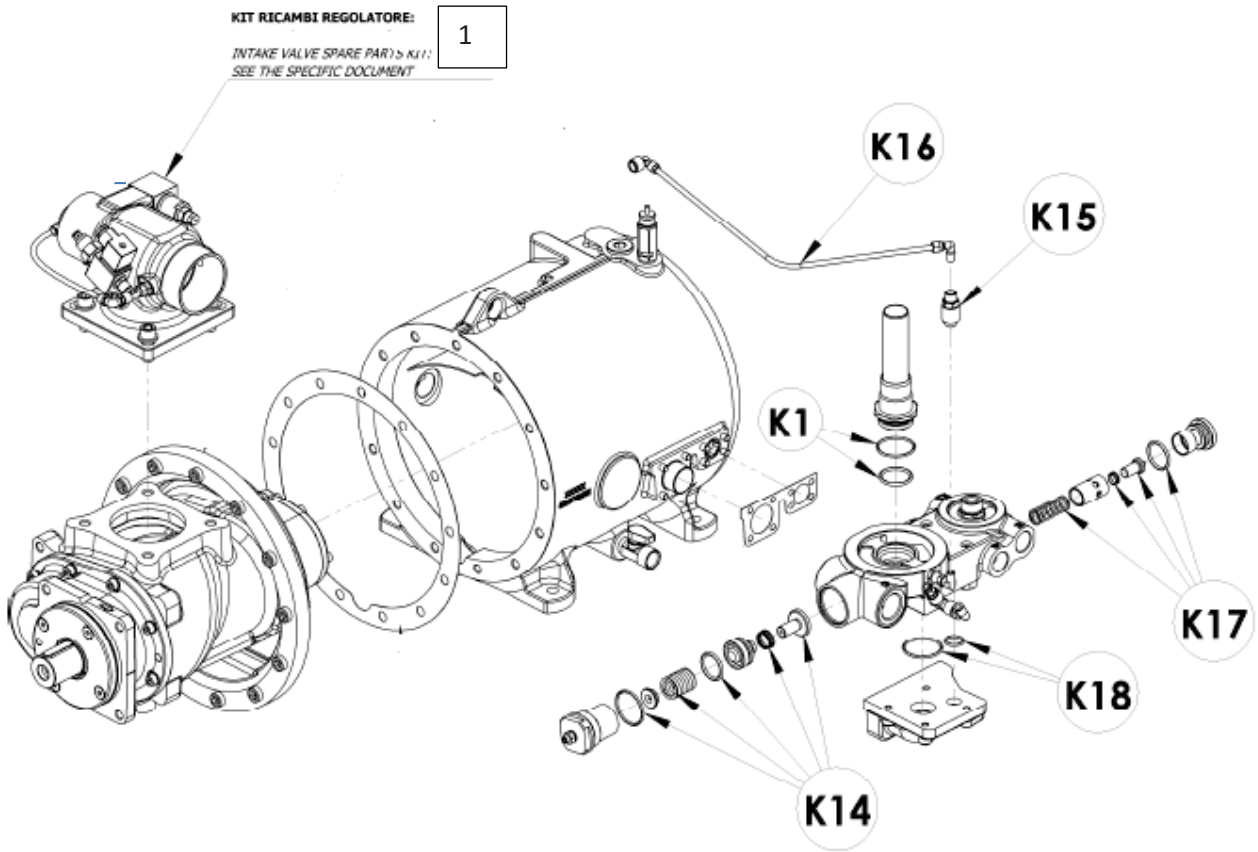

Figura 27

Ref.	Cod.	I	F	GB	D	E	Note
K1	3236033	KIT RICAMBI	KIT RECHANGE	KIT SPARE PARTS	KIT ERSATZTEILLE	KIT REFACIONES	
2	3236032	ELETTROVALVOLA	ELECTROVANNE	SOLENOID VALVE	SOLENOIDVENTILS	VALVULA DE SOLENOIDE	
K4	3236034	KIT VALVOLA	KIT VANNES	KIT VALVE	KIT VENTILE	KIT VALVULAS	

Tabella 31(Figura 27)

TUBI MATERIALE ATTACCHI A CAMME
TUBES MATÉRIAU RACCORDS À CAMES
MATERIAL PIPES WITH CAM COUPLINGS
MATERIALSCHLÄUCHE NOCKENANSCHLÜSSE
TUBOS MATERIAL CONEXIONES DE LEVAS

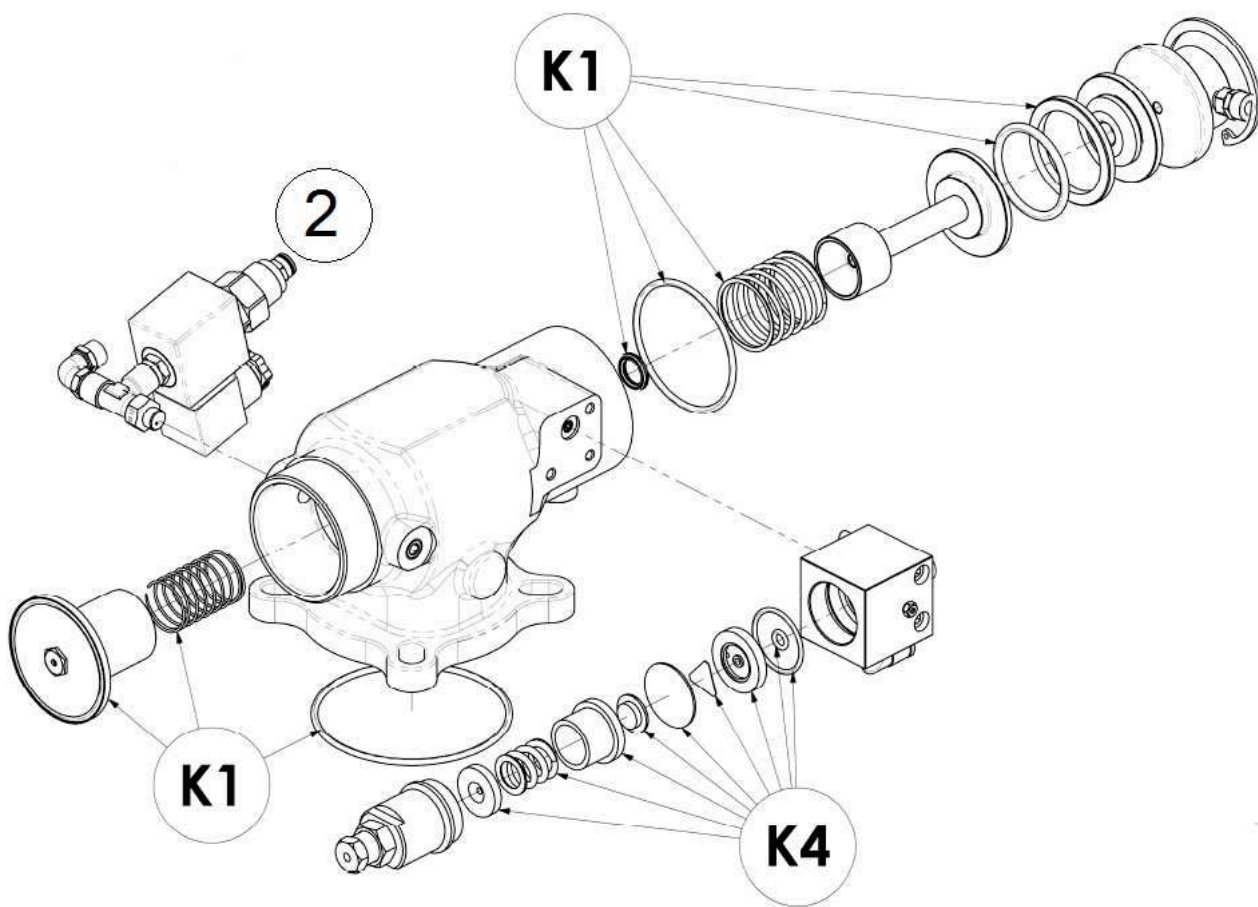
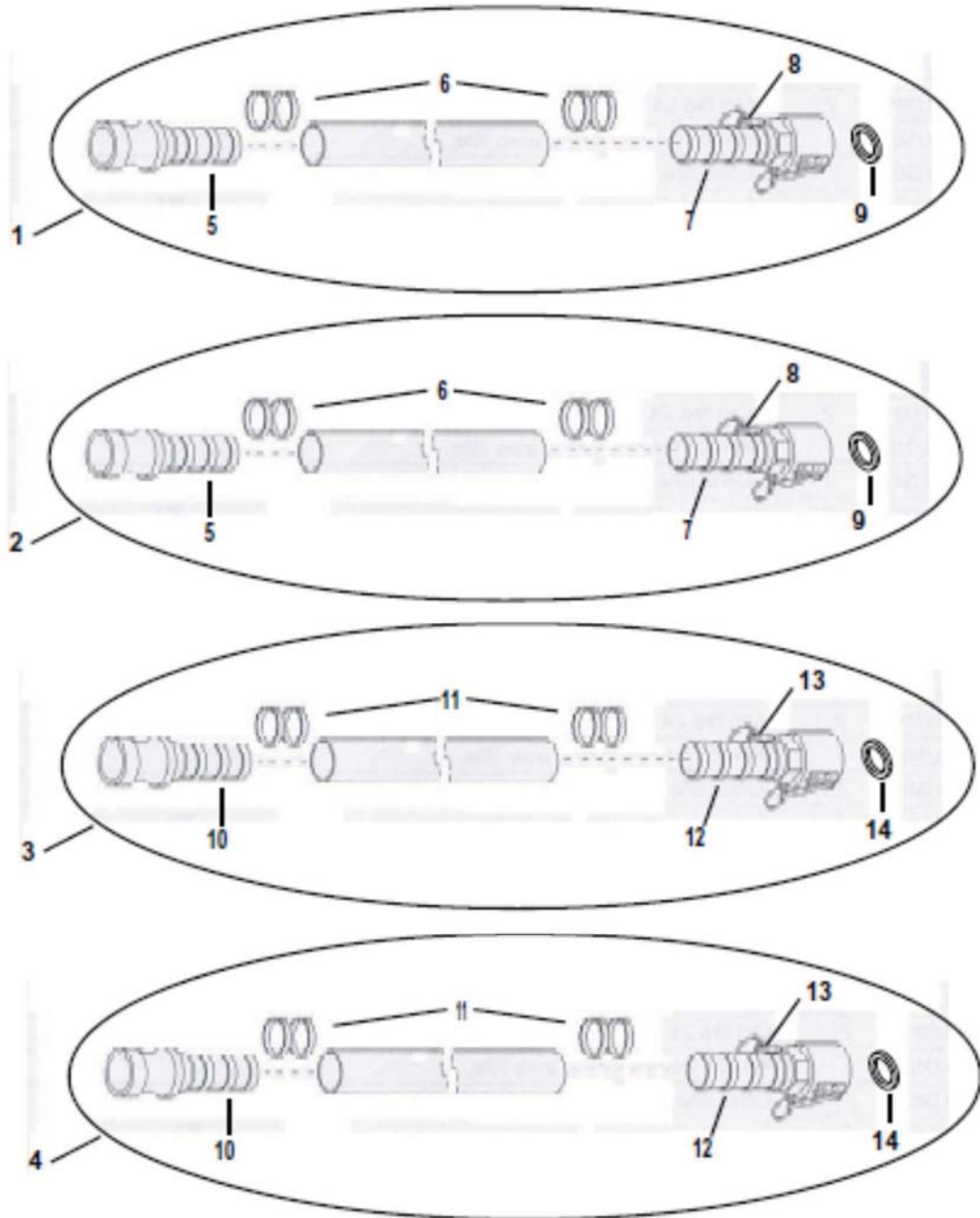

Fig. 28

Ref.	Cod.	I	F	GB	D	E	Note
1	1107536	TUBO 20 MT PORTAMATERIALE D60 CON ATTACCHI A CAMME	TUYAU 20 M DE REFOULEMENT D60 AVEC RACCORDS À CAMES	MATERIAL PIPE 20 MT D60 CON WITH CAM COUPLINGS	MATERIALFÖRDERSCHLAUCH (20 M) D60 MIT NOCKENANSCHLÜSSEN	TUBO 20 M PORTAMATERIAL D60 CON CONEXIONES DE LEVAS	
2	1107535	TUBO 10 MT PORTAMATERIALE D60 CON ATTACCHI A CAMME	TUYAU 10 M DE REFOULEMENT D60 AVEC RACCORDS À CAMES	MATERIAL PIPE 10 MT D60 CON WITH CAM COUPLINGS	MATERIALFÖRDERSCHLAUCH (10 M) D60 MIT NOCKENANSCHLÜSSEN	TUBO 10 M PORTAMATERIAL D60 CON CONEXIONES DE LEVAS	
3	1107534	TUBO 20 MT PORTAMATERIALE D50 CON ATTACCHI A CAMME	TUYAU 20 M DE REFOULEMENT D50 AVEC RACCORDS À CAMES	MATERIAL PIPE 20 MT D50 CON WITH CAM COUPLINGS	MATERIALFÖRDERSCHLAUCH (20 M) D50 MIT NOCKENANSCHLÜSSEN	TUBO 20 M PORTAMATERIAL D50 CON CONEXIONES DE LEVAS	
4	1107533	TUBO 10 MT PORTAMATERIALE D50 CON ATTACCHI A CAMME	TUYAU 10 M DE REFOULEMENT D50 AVEC RACCORDS À CAMES	MATERIAL PIPE 10 MT D50 CON WITH CAM COUPLINGS	MATERIALFÖRDERSCHLAUCH (10 M) D50 MIT NOCKENANSCHLÜSSEN	TUBO 10 M PORTAMATERIAL D50 CON CONEXIONES DE LEVAS	
5	3225931	RACCORDO KAMLOCK A FASCETTARE DN 65	RACCORD KAMLOCK À LIGATURER DN 65	KAMLOCK COUPLER FOR CLAMPING DN 65	KAMLOCK-KUPPLUNG (ARRETIERUNG MITTELS SCHELLE) DN 65	RACOR CAMLOCK A FIJAR CON ABRAZADERA DN 65	
6	3225945	MORSETTO STRINGITUBO 74-79	COLLIER SERRE-TUBE 74-79	PIPE CLAMP 74-79	SCHLAUCHKLEMME 74-79	MORDAZA ABRADAZARA 74-79	
7	3225932	RACCORDO KAMLOCK A FASCETTARE DN65F	RACCORD KAMLOCK À LIGATURER DN65F	KAMLOCK COUPLER FOR CLAMPING DN65F	KAMLOCK-KUPPLUNG (ARRETIERUNG MITTELS SCHELLE) DN 65F	RACOR CAMLOCK A FIJAR CON ABRAZADERA DN65F	
8	3226466	LEVA	LEVIER	LEVER	HEBEL	PALANCA	
9	3225891	GUARNIZIONE ATTACCO A CAMME DN 65	JOINT RACCORD À CAMES DN 65	CAM COUPLING GASKET DN 65	DICHTUNG NOCKENANSCHLUSS DN 65	EMPALME DE LEVAS DN 65	
10	3225937	RACCORDO KAMLOCK A FASCETTARE DN 50 M	RACCORD KAMLOCK À LIGATURER DN 50 M	KAMLOCK COUPLER FOR CLAMPING DN 50 M	KAMLOCK-KUPPLUNG (ARRETIERUNG MITTELS SCHELLE) DN 50 M	RACOR CAMLOCK A FIJAR CON ABRAZADERA DN 50M	
11	3225944	MORSETTO STRINGITUBO 60-76	COLLIER SERRE-TUBE 60-76	PIPE CLAMP 60-76	SCHLAUCHKLEMME 60-76	MORDAZA ABRADAZARA 60-76	
12	3225938	RACCORDO KAMLOCK A FASCETTARE DN 50 F	RACCORD KAMLOCK À LIGATURER DN 50 F	KAMLOCK COUPLER FOR CLAMPING DN 50 F	KAMLOCK-KUPPLUNG (ARRETIERUNG MITTELS SCHELLE) DN 50 F	RACOR CAMLOCK A FIJAR CON ABRAZADERA DN 50 F	
13	3224498	LEVA	LEVIER	LEVER	HEBEL	PALANCA	
14	3224499	GUARNIZIONE ATTACCO A CAMME DN50	JOINT RACCORD À CAMES DN50	CAM COUPLING GASKET DN50	DICHTUNG NOCKENANSCHLUSS DN50	EMPALME DE LEVAS DN50	

Tab. 32 (Fig. 28)

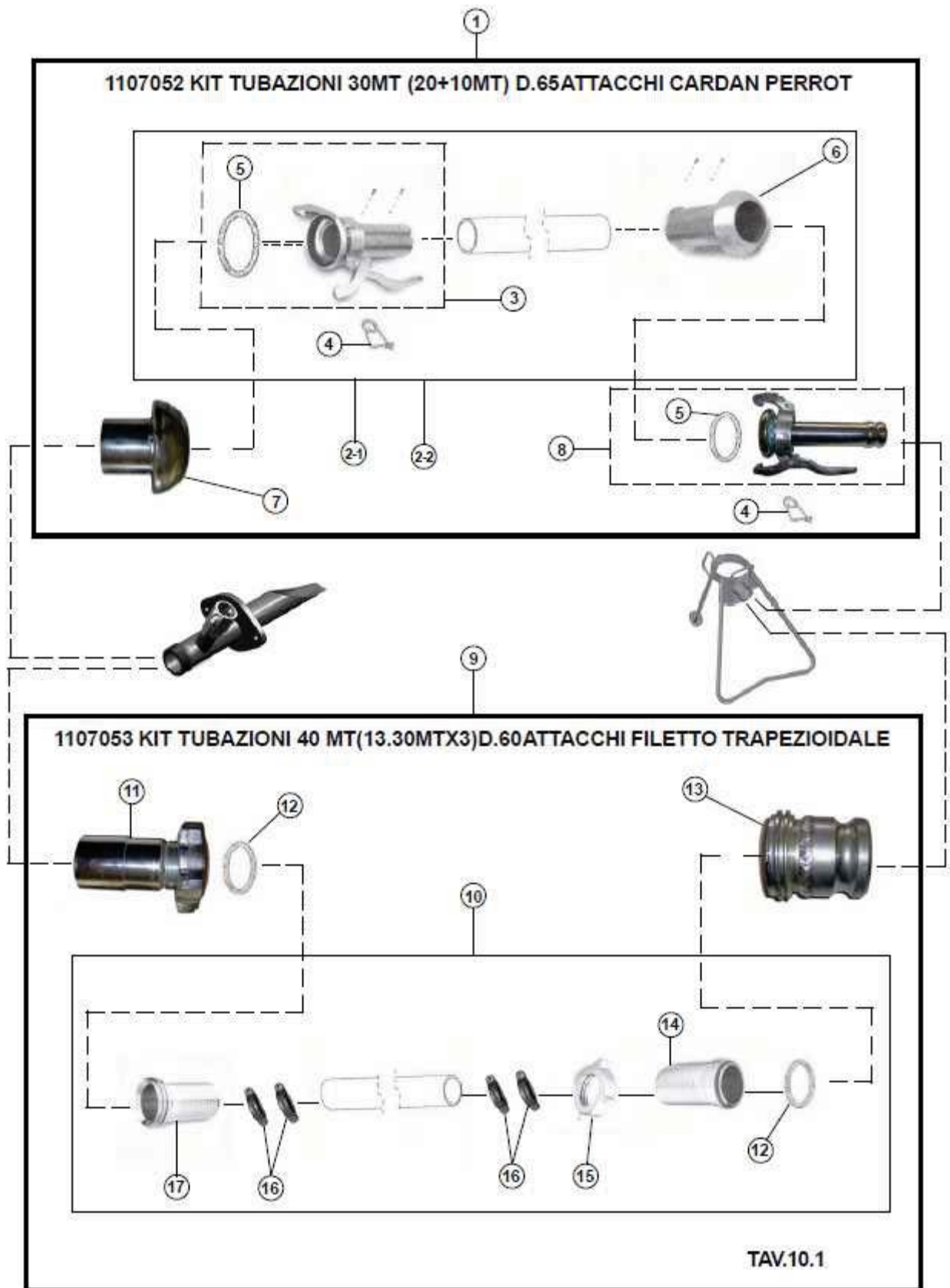

Fig. 29

Ref.	Cod.	I	F	GB	D	E	Note
1	1107052	KIT TUBI PORTAMATERIALE 30 MT D65 CON ATTACCHI CARDAN PERROT	KIT TUYAUX DE REFOULEMENT 30 M D65 AVEC RACCORDS CARDAN PERROT	MATERIAL PIPE 30 M D65 WITH CARDAN PERROT CONNECTIONS	SET MATERIALFÖRDERSCHLAUCH (30 M) D65 MIT CARDAN PERROT-KUPPLUNGEN	KIT TUBOS PORTAMATERIALE 30 M D65 CON CONEXIONES CARDAN PERROT	
2-1	1107096	TUBO 10 MT PORTAMATERIALE D.65X84 CON ATTACCHI CARDAN PERROT M.F. DN65	TUYAU 10 M DE REFOULEMENT D.65X84 AVEC RACCORDS CARDAN PERROT M.F. DN65	MATERIAL PIPE 10 MT D65X84 WITH M.F. CARDAN PERROT CONNECTIONS DN65	MATERIALFÖRDERSCHLAUCH (10 M) D.65X84 MIT CARDAN PERROT-KUPPLUNGEN S.B. DN65	TUBO 10 M PORTAMATERIALE D.65X84 CON CONEXIONES CARDAN PERROT M.H. DN65	
2-2	1107097	TUBO 20 MT PORTAMATERIALE D.65X84 CON ATTACCHI CARDAN PERROT M.F. DN65	TUYAU 20 M DE REFOULEMENT D.65X84 AVEC RACCORDS CARDAN PERROT M.F. DN65	MATERIAL PIPE 20 MT D65X84 WITH M.F. CARDAN PERROT CONNECTIONS DN65	MATERIALFÖRDERSCHLAUCH (20 M) D.65X84 MIT CARDAN PERROT-KUPPLUNGEN S.B. DN65	TUBO 20 M PORTAMATERIALE D.65X84 CON CONEXIONES CARDAN PERROT M.H. DN65	
3	3227222	RACCORDO CARDAN PERROT D.89 F	RACCORD CARDAN PERROT D.89 F	CARDAN PERROT FITTING D.89 F	CARDAN PERROT-KUPPLUNG D.89 F.	RACOR CARDAN PERROT D.89 F	
4	3227223	SPINA DI SICUREZZA	GOUPILLE DE SÉCURITÉ	SAFETY PIN	SICHERHEITSTIFT	CLAVIJA DE SEGURIDAD	
5	3225954	GUARNIZIONE PER RACCORDO CARDAN PERROT D.89	JOINT POUR RACCORD CARDAN PERROT D.89	GASKET FOR CARDAN PERROT FITTING D.89	DICHTUNG FÜR CARDAN PERROT-KUPPLUNG D.89	JUNTA PARA RACOR CARDAN PERROT D.89	
6	3227224	RACCORDO CARDAN PERROT D.89 M	RACCORD CARDAN PERROT D.89 M	CARDAN PERROT FITTING D.89 M	CARDAN PERROT-KUPPLUNG D.89 M.	RACOR CARDAN PERROT D.89 m	
7	3225949	RACCORDO CARDAN PERROT M. D.89 - 2 1/2"	RACCORD CARDAN PERROT M. D.89 - 2 1/2"	CARDAN PERROT FITTING M D.89 - 2 1/2"	CARDAN PERROT-KUPPLUNG M. D.89 - 2 1/2"	RACOR CARDAN PERROT M. D.89 - 2 1/2"	
8	3225948	RIDUZIONE KAMLOCK M. DN.65 CARDAN PERROT F.D. 89	RÉDUCTION KAMLOCK M. DN.65 CARDAN PERROT F.D. 89	KAMLOCK REDUCTION M. DN.65 CARDAN PERROT F.D. 89	KAMLOCK-REDUZIERUNG M. DN.65 CARDAN PERROT F.D. 89	REDUCCIÓN CAMLOCK M. DN.65 CARDAN PERROT F.D. 89	
9	1107053	KIT TUBI PORTAMATERIALE 40 MT D.60 CON ATTACCHI FILETTATI	KIT TUYAUX DE REFOULEMENT 40 M D.60 AVEC RACCORDS FILETÉS	MATERIAL PIPE 40 M D60 WITH THREADED CONNECTIONS	SET MATERIALFÖRDERSCHLAUCH (40 M) D.60 MIT GEWINDEANSCHLÜSSEN	KIT TUBOS PORTAMATERIALE 40 M D.60 CON CONEXIONES ROSCADAS	
10	1107098	TUBO 13.3 MT PORTAMATERIALE D.60X79 CON ATTACCHI FILETTATI M.F.	TUYAU 13.3 M DE REFOULEMENT D.60X79 AVEC RACCORDS FILETÉS M.F.	MATERIAL PIPE 13.3 MT D60X79 WITH M.F. THREADED CONNECTIONS	MATERIALFÖRDERSCHLAUCH (13.3 M) D.60X79 MIT GEWINDEANSCHLÜSSEN S.B.	TUBO 13,3 M PORTAMATERIALE D.60X79 CON CONEXIONES ROSCADAS M.H.	
11	3225950	RIDUZIONE KAMLOCK M. DN 65 FILETTO TRAPEZZOIALE DN 60	RÉDUCTION KAMLOCK M. DN 65 FILET TRAPÉZOÏDAL DN 60	KAMLOCK REDUCTION M. DN 65 TRAPEZOIDAL THREAD DN 60	KAMLOCK-REDUZIERUNG M. DN 65 TRAPEZGEWINDE DN 60	REDUCCIÓN CAMLOCK M. DN 65 ROSCA TRAPEZOIDAL DN 60	
12	3225953	GUARNIZIONE PER RACCORDO FILETTATO	JOINT POUR RACCORD FILETÉ	GASKET FOR THREADED FITTING	DICHTUNG FÜR GEWINDEANSCHLUSS	JUNTA PARA RACOR ROSCADO	
13	3225946	RIDUZ.KAMLOCK DN65 M-DN60 M FILET.	RÉDUCT. KAMLOCK DN65 M-DN60 M FILET.	KAMLOCK REDUCTION DN65 M-DN60 M THREADED	KAMLOCK-REDUZ. DN65 M-DN60 GEWINDESTIFT	REDUC.CAMLOCK DN65 M-DN60 M ROSC.	
14	3227225	RACCORDO A FASCETTARE DN 60 FILETTATO F.	RACCORD À LIGATURER DN 60 FILETÉ F.	FITTING FOR CLAMPING DN 60 FEMALE THREAD	KUPPLUNG (ARRETIERUNG MITTELS SCHELLE) DN 60 GEWINDEAUFNAHME	RACOR A FIJAR CON ABRAZADERA DN 60 ROSCADO H.	
15	3227226	GIRELLA FILETTO TRAPEZZOIALE	POULIE FILET TRAPÉZOÏDAL	PULLEY TRAPEZOIDAL THREAD	DREHSCHIBE TRAPEZGEWINDE	CARRETE ROSCA TRAPEZOIDAL	
16	3225945	MORSETTO STRINGITUBO 74-79	COLLIER SERRE-TUBE 74-79	PIPE CLAMP 74-79	SCHLAUCHKLEMME 74-79	MORDAZA ABRADEZARA 74-79	
17	3227227	RACCORDO A FASCETTARE DN 60 FILETTATO MASCHIO	RACCORD À LIGATURER DN 60 FILETÉ M.	FITTING FOR CLAMPING DN 60 MALE THREAD	KUPPLUNG (ARRETIERUNG MITTELS SCHELLE) DN 60 GEWINDESTIFT	RACOR A FIJAR CON ABRAZADERA DN 60 ROSCADO MACHO	

Tab. 33 (Fig. 29)